

Instruction Manual



TSG 111 PAL Signal Generator (SN B020000 to B039999)

070-8367-04

Warning

The servicing instructions are for use by qualified personnel only. To avoid personal injury, do not perform any servicing unless you are qualified to do so. Refer to all safety summaries prior to performing service.



Copyright © Tektronix, Inc. All rights reserved.

Tektronix products are covered by U.S. and foreign patents, issued and pending. Information in this publication supercedes that in all previously published material. Specifications and price change privileges reserved.

Printed in the U.S.A.

Tektronix, Inc., P.O. Box 1000, Wilsonville, OR 97070-1000

TEKTRONIX and TEK are registered trademarks of Tektronix, Inc.

WARRANTY

Tektronix warrants that the products that it manufactures and sells will be free from defects in materials and workmanship for a period of one (1) year from the date of shipment. If a product proves defective during this warranty period, Tektronix, at its option, either will repair the defective product without charge for parts and labor, or will provide a replacement in exchange for the defective product.

In order to obtain service under this warranty, Customer must notify Tektronix of the defect before the expiration of the warranty period and make suitable arrangements for the performance of service. Customer shall be responsible for packing and shipping the defective product to the service center designated by Tektronix, with shipping charges prepaid. Tektronix shall pay for the return of the product to Customer if the shipment location is within the country in which the Tektronix service center is located. Customer shall be responsible for paying all shipping charges, duties, taxes, and any other charges for products returned to any other locations.

This warranty shall not apply to any defect, failure, or damage caused by improper use or improper or inadequate maintenance and care. Tektronix shall not be obligated to furnish service under this warranty a) to repair damage resulting from attempts by personnel other than Tektronix representatives to install, repair, or service the product; b) to repair damage resulting from improper use or connection to incompatible equipment; c) to service a product that has been modified or integrated with other products when the effect of such modification or integration increases the time or difficulty of servicing the product.

THIS WARRANTY IS GIVEN BY TEKTRONIX WITH RESPECT TO THIS PRODUCT IN LIEU OF ANY OTHER WARRANTIES, EXPRESS OR IMPLIED. TEKTRONIX AND ITS VENDORS DISPLAY ANY IMPLIED WARRANTIES OF MERCHANTABILITY OR FITNESS FOR A PARTICULAR PURPOSE. TEKTRONIX'S RESPONSIBILITY TO REPAIR OR REPLACE DEFECTIVE PRODUCTS IS THE SOLE AND EXCLUSIVE REMEDY PROVIDED TO THE CUSTOMER FOR BREACH OF THIS WARRANTY. TEKTRONIX AND ITS VENDORS WILL NOT BE LIABLE FOR AND INDIRECT, SPECIAL, INCIDENTAL, OR CONSEQUENTIAL DAMAGES IRRESPECTIVE OF WHETHER TEKTRONIX OR THE VENDOR HAS ADVANCE NOTICE OF THE POSSIBILITY OF SUCH DAMAGES.

Service Assurance

If you have not already purchased Service Assurance for this product, you may do so at any time during the product's warranty period. Service Assurance provides Repair Protection and Calibration Services to meet your needs.

Repair Protection extends priority repair services beyond the product's warranty period; you may purchase up to three years of Repair Protection.

Calibration Services provide annual calibration of your product, standards compliance and required audit documentation, recall assurance, and reminder notification of scheduled calibration. Coverage begins upon registration; you may purchase up to five years of Calibration Services.

Service Assurance Advantages

- Priced well below the cost of a single repair or calibration
- Avoid delays for service by eliminating the need for separate purchase authorizations from your company
- Eliminates unexpected service expenses

For Information and Ordering

For more information or to order Service Assurance, contact your Tektronix representative and provide the information below. Service Assurance may not be available in locations outside the United States of America.

Name	VISA or Master Card number and expiration
Company	date or purchase order number
Address	Repair Protection (1,2, or 3 years)
City, State, Postal code	Calibration Services (1,2,3,4, or 5 years)
Country	Instrument model and serial number
Phone	Instrument purchase date

Table of Contents

	General Safety Summary	vii
	Service Safety Summary	ix
Getting Started		
	Introduction	1-1
	Physical Description	1-2
	Options	1-2
	Controls, Connections, Jumpers, and Switches	1-3
Specifications		
	Reference Documentation	2-1
	Performance Conditions	2-1
	Safety Standards	2-2
Theory of Operation		
	Front Panel <1>	3-2
	Digital Generation and Clock <2>	3-3
	Signal Memory <3>	3-4
	Digital Modulator and Lookup Table <4>	3-5
	Analog Outputs <5>	3-6
	Audio Tone <7>	3-6
	Power Supply <8>	3-8
Performance Verification		
	Equipment List	4-1
	Performance Verification Checklist	4-2
	Performance Verification Procedures	4-3
Adjustment Procedures		
	Adjustment Procedure Checklist	5-1
	Adjustment Procedures	5-1
Maintenance		
	Selecting Power Supply Mains Voltage	6-1
	Removing and Replacing the Audio Board	6-2
Replaceable Electrical Parts		
	Parts Ordering Information	7-1
	Using the Replaceable Electrical Parts List	7-1

Cross Index–Mfr. Code Number to Manufacturer	7-1
Abbreviations	7-1
List of Assemblies	7-1
Column Descriptions	7-2
Component No. (Column 1)	7-2
Tektronix Part No. (Column 2)	7-2
Serial/Assembly No. (Column 3 and 4)	7-2
Name and Description (Column 5)	7-2
Mfr. Code (Column 6)	7-2
Mfr. Part No. (Column 7)	7-2
Cross Index – Mfr. Code Number To Manufacturer	7-3
Replaceable Electrical Parts	7-5

Diagrams

Replaceable Mechanical Parts

Parts Ordering Information	9-1
Using the Replaceable Mechanical Parts List	9-1
Cross Index–Mfr. Code Number to Manufacturer	9-1
Abbreviations	9-1
Chassis Parts	9-1
Column Descriptions	9-2
Figure & Index No. (Column 1)	9-2
Tektronix Part No. (Column 2)	9-2
Serial No. (Column 3 and 4)	9-2
Qty (Column 5)	9-2
Name and Description (Column 6)	9-2
Mfr. Code (Column 7)	9-2
Mfr. Part Number (Column 8)	9-2
Cross Index – Mfr. Code Number To Manufacturer	9-3
Replaceable Mechanical Parts	9-4

List of Figures

Figure 1–1: TSG 111 front panel	1–1
Figure 1–2: TSG 111 rear panel	1–1
Figure 1–3: TSG 111 front panel	1–3
Figure 1–4: TSG 111 rear panel	1–4
Figure 2–1: 75% Color Bars	2–9
Figure 2–2: 75% Red	2–10
Figure 2–3: 100% Color Bars	2–10
Figure 2–4: 100% Red	2–11
Figure 2–5: 5–Step (Gray Scale)	2–11
Figure 2–6: Sin(x)/x	2–12
Figure 2–7: Convergence (vertical)	2–12
Figure 2–8: Convergence (horizontal)	2–13
Figure 2–9: Ramp	2–13
Figure 2–10: Modulated Ramp	2–14
Figure 2–11: Line Sweep	2–14
Figure 2–12: Pluge	2–15
Figure 2–13: CCIR 17	2–15
Figure 2–14: CCIR 18 (Multiburst)	2–16
Figure 2–15: CCIR 330	2–16
Figure 2–16: CCIR 331	2–17
Figure 2–17: UK ITS 1	2–17
Figure 2–18: UK ITS 2	2–18
Figure 2–19: 50% Field	2–18
Figure 2–20: 15 kHz Square Wave	2–19
Figure 2–21: Shallow Ramp	2–19
Figure 2–22: Black Burst (Option 02)	2–20
Figure 3–1: TSG 111 block diagram	3–1
Figure 3–2: Front Panel block diagram <1>	3–2
Figure 3–3: Digital generation and Clock block diagram <2>	3–2
Figure 3–4: Signal Memory block diagram <3>	3–4
Figure 3–5: Digital Modulator and Lookup Table block <4>	3–5
Figure 3–6: Analog Output block diagram <5>	3–5
Figure 3–7: The Audio circuit <7>	3–6
Figure 3–8: Power Supply block diagram<8>	3–7

Figure 4–1: Setup to verify crystal frequency	4–3
Figure 4–2: Basic setup for Performance Checks	4–4
Figure 4–3: Setup to measure total harmonic distortion (THD)	4–9
Figure 5–1: Setup to adjust oscillator frequency	5–2
Figure 5–2: Audio amplitude calibration setup	5–3
Figure 5–3: Audio ID click frequency adjustment setup	5–4
Figure 5–4: Basic setup for adjustment procedures	5–5
Figure 6–1: Remove 5 Pozidriv screws to remove Audio board	6–2

List of Tables

Table 1–1: TSG 111 test signal summary (Front Panel Matrix)	1–2
Table 1–2: TSG 111 jumper list and function	1–5
Table 2–1: General test signal characteristics	2–2
Table 2–2: Test signals	2–4
Table 2–3: Black burst characteristics (Option 02)	2–6
Table 2–4: Power supply specifications	2–6
Table 2–5: Audio Tone Characteristics	2–7
Table 2–6: Physical characteristics	2–7
Table 2–7: Environmental characteristics	2–8
Table 2–8: Certifications and compliances	2–8
Table 4–1: Performance verification equipment list	4–1
Table 4–2: Performance verification summary	4–2
Table 4–3: Basic setup for the 1781	4–4
Table 5–1: Setup for AA501 Distortion Analyzer	5–3
Table 5–2: Initial 1781 setup	5–5

General Safety Summary

Review the following safety precautions to avoid injury and prevent damage to this product or any products connected to it. To avoid potential hazards, use this product only as specified.

Only qualified personnel should perform service procedures.

To Avoid Fire or Personal Injury

Use Proper Power Cord. Use only the power cord specified for this product and certified for the country of use.

Connect and Disconnect Properly. Do not connect or disconnect probes or test leads while they are connected to a voltage source.

Ground the Product. This product is grounded through the grounding conductor of the power cord. To avoid electric shock, the grounding conductor must be connected to earth ground. Before making connections to the input or output terminals of the product, ensure that the product is properly grounded.

Observe All Terminal Ratings. To avoid fire or shock hazard, observe all ratings and markings on the product. Consult the product manual for further ratings information before making connections to the product.

Do not apply a potential to any terminal, including the common terminal, that exceeds the maximum rating of that terminal.

Do Not Operate Without Covers. Do not operate this product with covers or panels removed.

Use Proper Fuse. Use only the fuse type and rating specified for this product.

Avoid Exposed Circuitry. Do not touch exposed connections and components when power is present.

Do Not Operate With Suspected Failures. If you suspect there is damage to this product, have it inspected by qualified service personnel.

Do Not Operate in Wet/Damp Conditions.

Do Not Operate in an Explosive Atmosphere.

Keep Product Surfaces Clean and Dry.

Provide Proper Ventilation. Refer to the manual's installation instructions for details on installing the product so it has proper ventilation.

Symbols and Terms

Terms in this Manual. These terms may appear in this manual:



WARNING. Warning statements identify conditions or practices that could result in injury or loss of life.



CAUTION. Caution statements identify conditions or practices that could result in damage to this product or other property.

Terms on the Product. These terms may appear on the product:

DANGER indicates an injury hazard immediately accessible as you read the marking.

WARNING indicates an injury hazard not immediately accessible as you read the marking.

CAUTION indicates a hazard to property including the product.

Symbols on the Product. The following symbols may appear on the product:



WARNING
High Voltage



Protective Ground
(Earth) Terminal



CAUTION
Refer to Manual



Double
Insulated

Service Safety Summary

Only qualified personnel should perform service procedures. Read this *Service Safety Summary* and the *General Safety Summary* before performing any service procedures.

Do Not Service Alone. Do not perform internal service or adjustments of this product unless another person capable of rendering first aid and resuscitation is present.

Disconnect Power. To avoid electric shock, disconnect the mains power by means of the power cord or, if provided, the power switch.

Use Care When Servicing With Power On. Dangerous voltages or currents may exist in this product. Disconnect power, remove battery (if applicable), and disconnect test leads before removing protective panels, soldering, or replacing components.

To avoid electric shock, do not touch exposed connections.



Getting Started

Getting Started

Introduction

The TSG 111 PAL Signal Generator is a simple, cost-effective test signal generator designed for the service environment. The TSG 111 digitally generates a full complement of test signals in PAL format.

Table 1-1 lists the test signals supplied by the TSG 111.

Besides a full complement of video signals in three formats, the TSG 111 supplies two channels of a balanced 1 kHz XLR-audio tone with jumper-selectable ID click. The frequency of the ID click is adjustable.

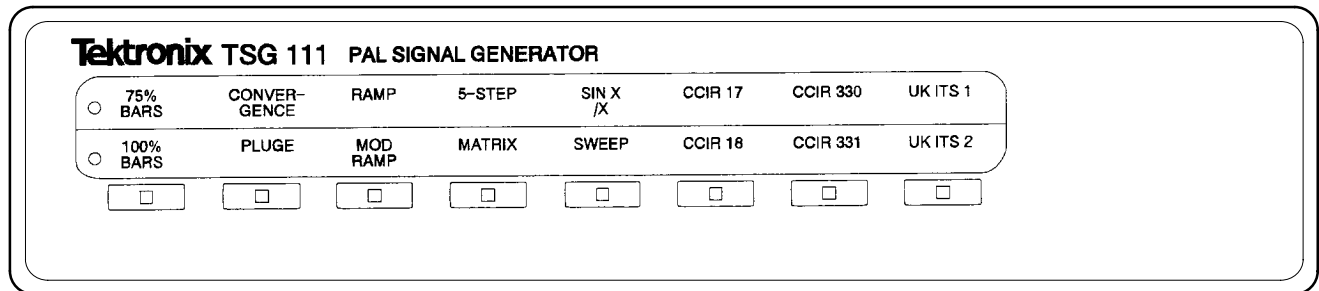

Figure 1-1: TSG 111 front panel

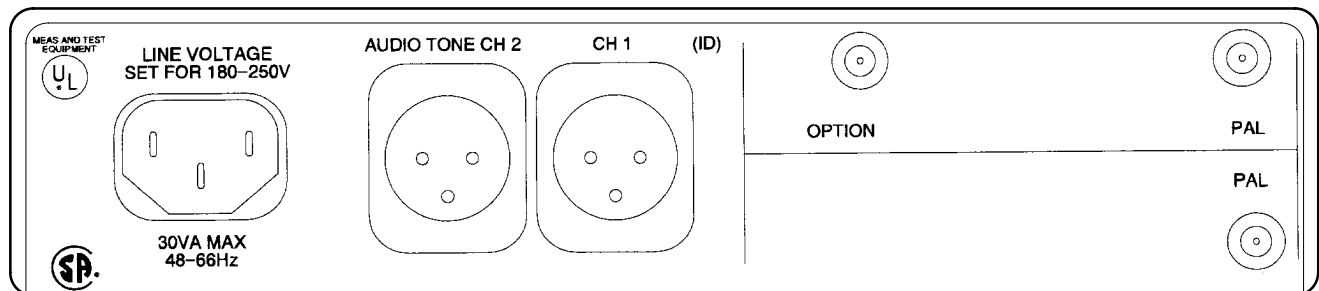

Figure 1-2: TSG 111 rear panel

Table 1-1: TSG 111 test signal summary (Front Panel Matrix)

Test Signal (Top Row)	Test Signal (Bottom Row)
75% Color Bars over Red	100% Color Bars over Red
Convergence	Pluge
Ramp	Modulated Ramp
5-Step	Matrix
Sin(x)/x	Line Sweep
CCIR 17	CCIR 18 (Multiburst)
CCIR 330	CCIR 331
UK ITS 1	UK ITS 2

Physical Description

The TSG 111 consists of four circuit boards and three cables in a rectangular sheet-aluminum chassis with a removeable top cover. The major internal components are:

1. A main board that performs most of the TSG 111's functions.
2. A front panel board that decodes front-panel button selections.
3. A ribbon cable that feeds decoded front-panel information to the main board.
4. A ribbon cable that supplies signals from the main board to the top BNC connector mounting board.
5. Two BNC connector mounting boards:
 - The top board contains one SVHS and three BNC connectors
 - The bottom board contains three BNC connectors.
6. A ribbon cable that supplies signals from the main board to the bottom BNC connector mounting board.
7. Audio board to supply audio signal and the ID click.
8. Cable to supply power to audio.

Options

TSG 111 options consist of Options 01, 02, and 10. These are described in the following sections. Options 01, 02, and 10 may be ordered in any combination.

Option 01 This option adds the CCIR 17, CCIR 18, CCIR 330, and CCIR 331 signals to the appropriate lines in the vertical interval. Option 01 also changes the Matrix test pattern to include only six of the twelve signals used in the standard instrument.

The six signals for Option 01 are: CCIR 17, CCIR 18, CCIR 330, CCIR 331, BARS 75%, and SIN(x)/x.

Option 02 This option adds a dedicated Black Burst Output channel, available at the rear panel OPTION connector.

Option 10 This option provides a tighter tolerance for the internal subcarrier reference. The Option 10 subcarrier is $F_{sc} \pm 5$ Hz instead of the standard $F_{sc} \pm 10$ Hz.

Controls, Connections, Jumpers, and Switches

This section describes the front and rear panel controls, connections, jumpers, and switches. For information on configuring the power supply for 110 VAC or 220 VAC operation, see the Maintenance section.



CAUTION. The TSG 111 is shipped from the factory configured for 220 VAC operation. Attempting to operate the TSG 111 at any other voltage without reconfiguring the power supply may cause damage. Refer to Selecting Power Supply Mains Voltage, page 6-1 for further information.

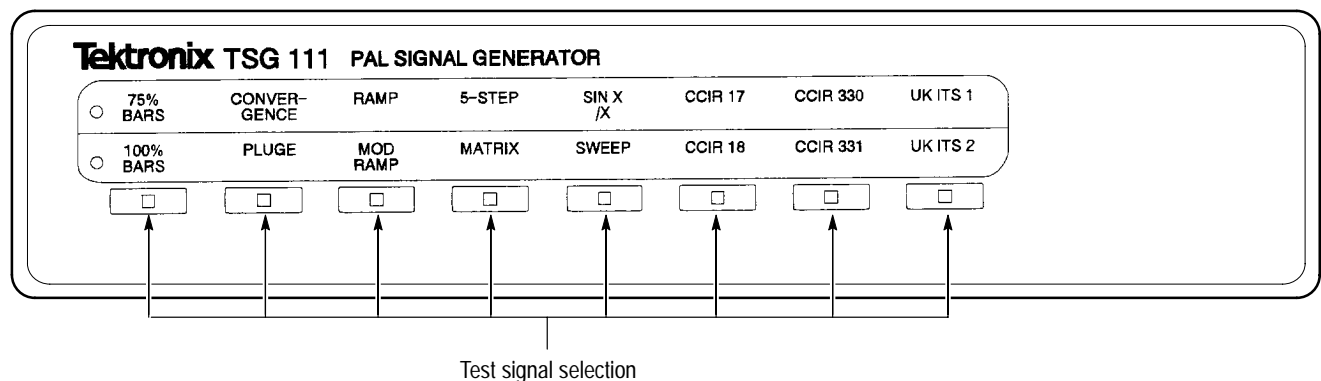

Figure 1-3: TSG 111 front panel

Front Panel Controls

The front panel contains eight Test-Signal Selection buttons. Above the buttons are two rows of test signal selections, arranged in columns. On the left side are

two LEDs, one for each row. These LEDs indicate the test signal row selected. Pressing a Test-Signal Selection button for the first time lights the top-row LED. Successive presses of the same button selects the other test signal in the column.

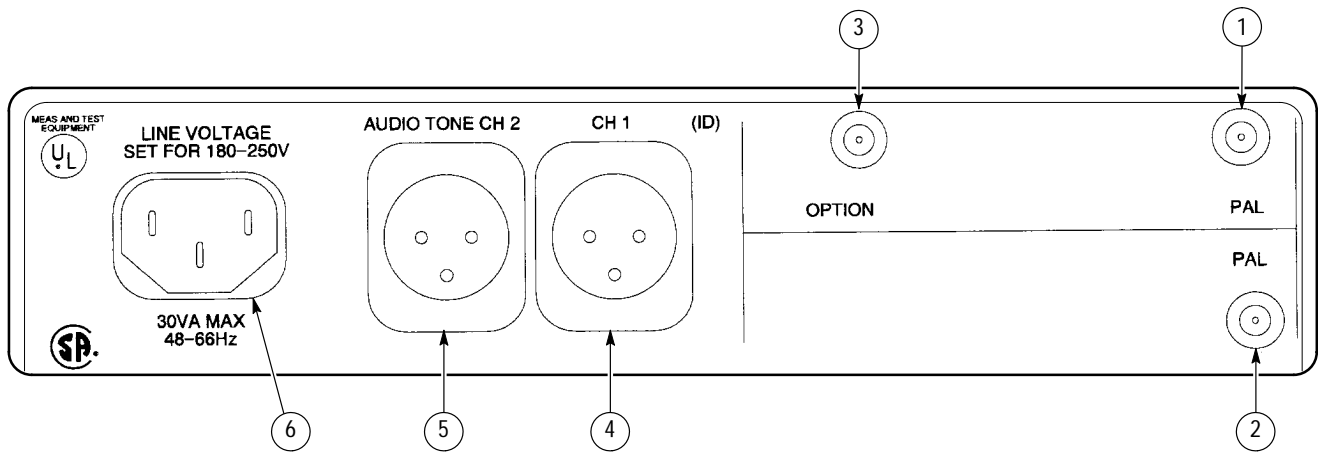

Figure 1-4: TSG 111 rear panel

Rear Panel Connections

This section describes the TSG 111 connections and adjustments.

1. PAL test signal output.
2. PAL test signal output.
3. OPTION – dedicated Black Burst Output channel (Option 02).
4. 1 kHz audio tone output with jumper-selectable ID click (see jumper table and adjustment procedure in Adjustment Procedures section).
5. 1 kHz audio tone output in phase with CH 1.
6. Electrical mains input, factory set for 220 VAC (to change power supply operating voltage, see *Configuring the Power Supply*).

Audio Tone ID

The TSG 111's audio tone output is a balanced 1 kHz XLR audio tone. Audio output gain is adjustable (see *Adjustment Procedures* in section 5.).

A channel ID click is provided on CH 1. The frequency of the ID click may be changed, or the click may be disabled. To change the frequency of the ID click, see the *Calibration Procedures*. To disable the ID click, see Table 1-2.

Jumpers and Switches

Table 1-2 describes the TSG 111 jumpers.

Table 1-2: TSG 111 jumper list and function

Jumper	Position	Function
J112	1-2	Enables standard front panel operation.
	2-3	Allows selecting diagnostic test signals.
J110	1-2	Field 1, Line 7 white flag enable.
	2-3	Field 1, Line 7 white flag disable.
J111	1-2	For future use.
	2-3	For future use.
J108	1-2	System clock enable.
	2-3	System clock disable.
J6	1-2	Normal.
	2-3	PAL output disable.
J12	1-2	Audio Click enable.
	2-3	Audio Click disable.
J40	1-2	+12V supply enable/disable.
J50	1-2	-12V supply enable/disable.
J60	1-2	+5V supply enable/disable.
J70	1-2	-5V supply enable/disable.
J122	1-2-3-4	Power supply configured for 110 VAC operation.
	2-3-4-5	Power supply configured for 220 VAC operation.



Specifications

Specifications

The material in this section is organized into two main groupings: the specification tables and the supporting figures. The specification tables include:

1. PAL general and test signal specifications
2. Signal level specifications
3. Power supply, physical, and environmental specifications

The supporting figures (waveform diagrams and related data) follow the specification tables.

Reference Documentation

The following documents were used as references in the preparation of this specification:

1. Product Classification Environmental Test Summary, 13 June 1977; Tektronix Standard 062-2853-00
2. Electrostatic Discharge Environmental Test, 20 October 1977; Tektronix Standard 062-2862-00
3. Electromagnetic Compatibility Environmental Test, 31 March 1977; Tektronix Standard 062-2866-00
4. Recommendations and Reports of the CCIR, 1978; Transmission of Sound Broadcasting and Television Signals Over Long Distances (CMTT)
5. IEEE Standard Dictionary of Electrical Terms, Second Edition (1977); IEEE Standard 100-1977
6. Safety Standard for Electrical and Electronic Equipment, Draft 6, June 1978; ANSI C39.5
7. Canadian Standards Association Electrical Bulletin; CAN/CSA C22.2 No. 1010.1

Performance Conditions

The Performance Requirements are valid within the environmental limits if the instrument is adjusted at $25^{\circ}\text{C} \pm 5^{\circ}\text{C}$, and a minimum warm-up time of 20 minutes is allowed.

Safety Standards

The following safety standards apply to the TSG 111:

- UL 3111
- CAN/CSA C22.2 No. 231
- ANSI/ISA S82.02.01

NOTE. Any figures referenced in this section are found after the specification tables.

Table 2–1: General test signal characteristics

Characteristics	Performance requirements	Supplemental information	Performance check step no.
Luminance Amplitude Accuracy	$\pm 1\%$		6
Chrominance-to-Luminance Gain	$\pm 1\%$		9
Chrominance Accuracy	$\pm 1\%$		7
DC Level	0 mV \pm 50 mV		2
Luminance Rise Time	250 ns \pm 25 ns	Except Color Bars, 2T Bar, and Convergence.	
Chrominance Rise Time	350 ns \pm 35 ns		
Burst Amplitude	300 mV \pm 6 mV _{p-p}		4
Burst Rise Time	350 ns \pm 35 ns	Slower than BBC spec to avoid ringing.	
Sync Amplitude	300 mV \pm 30 mV		3
Sync Rise Time	250 ns \pm 25 ns		10
Horizontal Timing	See Figures 2–1 to 2–6.	All signals comply with PAL timing specs.	
Front Porch Duration	1.55 μ s minimum		
Line Blanking Interval	12.0 μ s \pm 1.15 μ s	Beginning at 50% point of active video.	12
Breezeway Duration	900 ns \pm 50 ns		
Horizontal Sync Duration	4.7 μ s \pm 50 ns	50% amplitude point.	11
Vertical Serration Duration	4.7 μ s \pm 50 ns	50% amplitude point.	11
Equalizing Pulse Duration	2.35 μ s \pm 50 ns	50% amplitude point.	11
Burst Delay from Sync Burst Duration	5.6 μ s \pm 50 ns 2.255 μ s \pm 0.1 μ s	From 50% point of sync. 10 subcarrier cycles.	
Output Impedance	75 Ω		

Table 2-1: General test signal characteristics (cont.)

Characteristics	Performance requirements	Supplemental information	Performance check step no.
Return Loss		≥ 36 dB to 5 MHz	
Crosstalk		≥ 60 dB down	
Residual Subcarrier		≥ 60 dB down	
Oscillator Frequency Stability Normal Option 10	$F_{\text{clk}} \pm 40$ Hz over 5 °C to 35 °C $F_{\text{clk}} \pm 20$ Hz over 5 °C to 35 °C	$F_{\text{clk}} = 17.734375$ MHz	1
Subcarrier Frequency Stability Normal Option 10	$F_{\text{sc}} \pm 10$ Hz over 5 °C to 35 °C $F_{\text{sc}} \pm 5$ Hz over 5 °C to 35 °C	$F_{\text{sc}} = \frac{1135 \text{ H} + 100}{4}$ $= 4.43361875$ MHz	
SC/H Accuracy	$0^\circ \pm 5^\circ$		15
Chrominance-to-Luminance Delay	≤ 5 ns		8
Frequency Response	2% to 5 MHz		13

Table 2-2: Test signals

Characteristics	Performance requirements	Supplemental information	Performance check step no.																											
75% Color Bars over Red Luminance Rise Times Field Timing Color Bars Red	150 ns ± 25 ns Lines 24 – 166 and 336 – 479 Lines 167 – 310 and 480 – 622 <table border="1"> <thead> <tr> <th>Luminance Amplitude</th> <th>Subcarrier Amplitude</th> <th>Subcarrier Phase</th> </tr> <tr> <th><i>mV</i></th> <th><i>mV_{p-p}</i></th> <th><i>Degree</i></th> </tr> </thead> <tbody> <tr> <td>White</td> <td>000.0</td> <td>000.0</td> </tr> <tr> <td>Yellow</td> <td>470.5</td> <td>167.1</td> </tr> <tr> <td>Cyan</td> <td>663.8</td> <td>283.5</td> </tr> <tr> <td>Green</td> <td>620.1</td> <td>240.7</td> </tr> <tr> <td>Magenta</td> <td>620.1</td> <td>60.7</td> </tr> <tr> <td>Red</td> <td>663.8</td> <td>103.5</td> </tr> <tr> <td>Blue</td> <td>470.5</td> <td>347.1</td> </tr> </tbody> </table>	Luminance Amplitude	Subcarrier Amplitude	Subcarrier Phase	<i>mV</i>	<i>mV_{p-p}</i>	<i>Degree</i>	White	000.0	000.0	Yellow	470.5	167.1	Cyan	663.8	283.5	Green	620.1	240.7	Magenta	620.1	60.7	Red	663.8	103.5	Blue	470.5	347.1	Figure 2-1 Figure 2-2	
Luminance Amplitude	Subcarrier Amplitude	Subcarrier Phase																												
<i>mV</i>	<i>mV_{p-p}</i>	<i>Degree</i>																												
White	000.0	000.0																												
Yellow	470.5	167.1																												
Cyan	663.8	283.5																												
Green	620.1	240.7																												
Magenta	620.1	60.7																												
Red	663.8	103.5																												
Blue	470.5	347.1																												
100% Color Bars over Red Luminance Rise Times Field Timing Color Bars Red	150 ns ± 25 ns Lines 24 – 166 and 336 – 479 Lines 167 – 310 and 480 – 622 <table border="1"> <thead> <tr> <th>Luminance Amplitude</th> <th>Subcarrier Amplitude</th> <th>Subcarrier Phase</th> </tr> <tr> <th><i>mV</i></th> <th><i>mV_{p-p}</i></th> <th><i>Degree</i></th> </tr> </thead> <tbody> <tr> <td>White</td> <td>000.0</td> <td>000.0</td> </tr> <tr> <td>Yellow</td> <td>627.3</td> <td>167.1</td> </tr> <tr> <td>Cyan</td> <td>885.1</td> <td>283.5</td> </tr> <tr> <td>Green</td> <td>826.8</td> <td>240.7</td> </tr> <tr> <td>Magenta</td> <td>826.8</td> <td>60.7</td> </tr> <tr> <td>Red</td> <td>885.1</td> <td>103.5</td> </tr> <tr> <td>Blue</td> <td>627.3</td> <td>347.1</td> </tr> </tbody> </table>	Luminance Amplitude	Subcarrier Amplitude	Subcarrier Phase	<i>mV</i>	<i>mV_{p-p}</i>	<i>Degree</i>	White	000.0	000.0	Yellow	627.3	167.1	Cyan	885.1	283.5	Green	826.8	240.7	Magenta	826.8	60.7	Red	885.1	103.5	Blue	627.3	347.1	Figure 2-3 Figure 2-4	
Luminance Amplitude	Subcarrier Amplitude	Subcarrier Phase																												
<i>mV</i>	<i>mV_{p-p}</i>	<i>Degree</i>																												
White	000.0	000.0																												
Yellow	627.3	167.1																												
Cyan	885.1	283.5																												
Green	826.8	240.7																												
Magenta	826.8	60.7																												
Red	885.1	103.5																												
Blue	627.3	347.1																												
Convergence Amplitude Pattern Pulse HAD	525.0 mV 14 lines/field and 19 lines/horiz 225 ns ± 25 ns	Figures 2-7, 2-8.																												
5-Step (Gray Scale) Amplitude Linearity Error	700 mV ≤1%	Figure 2-5.	5																											
Ramp/Modulated Ramp Luminance Amplitude Chrominance Amplitude Differential Gain Differential Phase	700 mV 280.0 mV _{p-p} 0.8% maximum 0.8° maximum	When averaged with a Tek 1781 or VM 700, the quantizing errors in the Mod Ramp are greatly reduced. This allows a more accurate measurement of dg and dφ errors. Figures 2-9, 2-10.	15 15																											

Table 2-2: Test signals (cont.)

Characteristics	Performance requirements	Supplemental information	Performance check step no.
Line Sweep Frequency Amplitude	500 kHz – 5.5 MHz 700 mV _{p-p}	Figure 2-11. Markers at 1, 2, 3, 4 and 5 MHz	
Pluge Matrix Pluge Levels Lum Ref Levels	-14 mV and +14 mV 700 mV, 450 mV, 200 mV, and 110 mV	Figure 2-12.	
CCIR 17 2T bar width rise time 2T pulse HAD 20T modulated pulse 5-step	10 μs 192.9 ns ±20 ns 200 ns ±20 ns 60.7°	Figure 2-13.	
CCIR 18 (Multiburst) White Reference Bar Amplitude Packet Amplitudes Pedestal Burst Frequencies Packet Rise Time	420 mV _{p-p} 420 mV _{p-p} 350 mV 0.5, 1.0, 2.0, 4.0, 4.8, and 5.8 MHz 350 ns typical	Figure 2-14. Equal width packets Sine squared shaped packets.	
CCIR 330 2T bar width 2T bar rise time 2T pulse HAD 5-Step with 280 mV _{p-p} modulation	10 μs 192.9 ns ±20 ns 200 ns ±20 ns 60.7°	Figure 2-15.	
CCIR 331 Luminance Pedestal Rise Time	350 mV luminance pedestal with three levels, 140 mV _{p-p} , 420 mV _{p-p} , and 700 mV _{p-p} , of chroma bar (60.7°) followed by 420 mV _{p-p} of chroma bar (60.7°). 192.9 ns ±20 ns	Figure 2-16.	
UK ITS 1	2T bar (width = 10 μs, rise time = 192.9 ns ±20 ns), 2T pulse (HAD = 200 ns ±20 ns), 10T modulated pulse (60.7°), and 5-Step with 140 mV _{p-p} modulation (60.7°).	Figure 2-17.	

Table 2-2: Test signals (cont.)

Characteristics	Performance requirements	Supplemental information	Performance check step no.
UK ITS 2 Luminance Pedestal Rise Time	700 mV _{p-p} 60.7° chroma bar on a 350 mV luminance pedestal. 280 mV _{p-p} 60.7° chroma bar (no pedestal). 192.9 ns ±20 ns	Figure 2-18.	
Matrix Standard	CCIR 17, CCIR 330, CCIR 331, CCIR 18, 75% Bars, Sin(x)/x, Red, 15 kHz Square Wave, 50% Field, Shallow Ramp, ITS 1, ITS 2.	Figures 2-13, 2-15, 2-16, 2-14, 2-1 2-6, 2-4, 2-20, 2-19, 2-21, 2-17, 2-18.	
Option 01	CCIR 17, CCIR 18, CCIR 330, CCIR 331, 75% Bars, Sin(x)/x.	Figures 2-13, 2-14, 2-15, 2-16, 2-1, 2-6.	

Table 2-3: Black burst characteristics (Option 02)

Characteristics	Performance requirements	Supplemental information
Black Amplitude	0 mV ±50 mV	Figure 2-22.
Blanking Width	12 μs ±0.15 μs	
Sync Timing	See Figure 2-22	

Table 2-4: Power supply specifications

Characteristics	Supplemental information
Supply accuracy +5V -5.2V +12V -12V	5V ±250 mV -5.2V +300 mV, -500 mV +12V ±600 mV -12V ±600 mV
Power limit	18 Watts
Hum +5V -5.2V +12V -12V	Typical 10 mV 20 mV 10 mV 10 mV

Table 2-4: Power supply specifications (cont.)

Characteristics	Supplemental information
Noise +5V -5.2V +12V -12V	± 50 mV (5 MHz bandwidth) ± 50 mV (5 MHz bandwidth) ± 50 mV (5 MHz bandwidth) ± 50 mV (5 MHz bandwidth)
Line voltage range 115 VAC 240 VAC	90 – 130 VAC 180 – 250 VAC
Fuse date 110 VAC Setting 220 VAC Setting	0.4 A Med. Blow 0.2 A Med. Blow
Power consumption, typical	15 Watts
Line frequency	48 – 62 Hz
DC input range	11 – 16 VDC

Table 2-5: Audio tone characteristics

Characteristics	Performance requirements	Performance check step no.
Amplitude	0 to +8 dBu into 600 Ω , or a high-impedance load.	
Frequency	1 kHz	
Distortion (THD)	$\leq 0.5\%$ THD	18
Audio ID "click" frequency range (one channel only)	Adjustable from 0.2 – 4 Hz.	

Table 2-6: Physical characteristics

Characteristics	Supplemental information
Dimensions Height Width Length	43.4 mm (1.71 in) 205.7 mm (8.10 in) 381.0 mm (15.0 in)
Net weight	1.47 kg (4 lbs, 6 oz)
Shipping weight	3.2 kg (7 lbs, 1 oz)

Table 2–7: Environmental characteristics

Characteristics	Supplemental information
Temperature Non-operating Operating	–40 to +65° C 0 to +35° C
Altitude Non-operating Operating	To 50,000 feet To 15,000 feet
Vibration (operating)	15 minutes each axis at 0.025 inch, with frequency varied from 10–55–10 cycles per second in 4-minute cycles, with instrument secured to vibration platform. Ten minutes each axis at any resonant point or at 55 cycles per second.
Shock	50 g, 1/2 sine, 11 ms duration, 3 guillotine-type shocks per side.
Transportation	Qualified under NTSB Test Procedure 1A, Category II (24-inch drop).

Table 2–8: Certifications and compliances

EC Declaration of Conformity - EMC	<p>Meets intent of Directive 89/336/EEC for Electromagnetic Compatibility. Compliance was demonstrated to the following specifications as listed in the Official Journal of the European Communities:</p> <p>EN 50081-1 Emissions: EN 55022 Class B Radiated and Conducted Emissions</p> <p>EN 50082-1 Immunity: IEC 801-2 Electrostatic Discharge Immunity IEC 801-3 RF Electromagnetic Field Immunity IEC 801-4 Electrical Fast Transient/Burst Immunity</p> <p>¹ Must use high-quality cables to insure compliance with advertised specifications.</p>
FCC Compliance	Emissions comply with FCC Code of Federal Regulations 47, Part 15, Subpart B, Class A Limits
EC Declaration of Conformity – Low Voltage	<p>Compliance was demonstrated to the following specification as listed in the Official Journal of the European Communities:</p> <p>Low Voltage Directive 73/23/EEC</p> <p>EN 61010-1:1993 Safety requirements for electrical equipment for measurement, control, and laboratory use</p> <p>EN 61010-2-031:1994 Particular requirements for hand-held probe assemblies for electrical measurement and test equipment</p> <p>EN 61010-2-032:1995 Particular requirements for hand-held current clamps for electrical measurements and test</p>
Safety Class	Class I (as defined in IEC 1010–1, Annex H) – grounded product
Overvoltage Category	Overvoltage Category II (as defined in IEC 1010–1, Annex J)
Pollution Degree	Pollution Degree 2 (as defined in IEC 1010–1) Note: Rated for indoor use only.

Table 2-8: Certifications and compliances (cont.)

<p>Approvals</p>	<p>ANSI/ISA S82.01 – Safety standard for electrical and electronic test, measuring, controlling, and related equipment, 1994</p> <p>UL3111-1 – Standard for electrical measuring and test equipment</p> <p>CAN/CSA C22.2 No. 1010.1 – Safety requirements for electrical equipment for measurement, control and laboratory use</p> <p>IEC1010-1 – Safety requirements for electrical equipment for measurement, control, and laboratory use</p>
<p>Installation Category Descriptions</p>	<p>Terminals on this product may have different installation category designations. The installation categories are:</p> <p>CAT III Distribution-level mains (usually permanently connected). Equipment at this level is typically in a fixed industrial location</p> <p>CAT II Local-level mains (wall sockets). Equipment at this level includes appliances, portable tools, and similar products. Equipment is usually cord-connected</p> <p>CAT I Secondary (signal level) or battery operated circuits of electronic equipment</p>

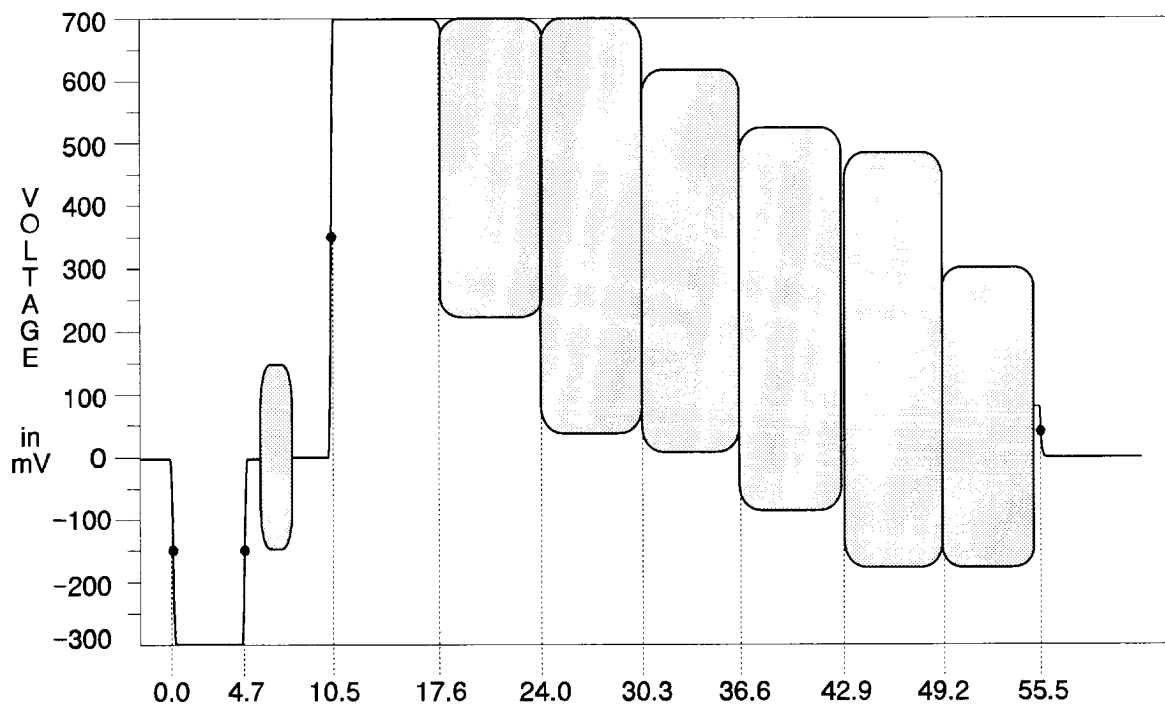

Figure 2-1: 75% color bars

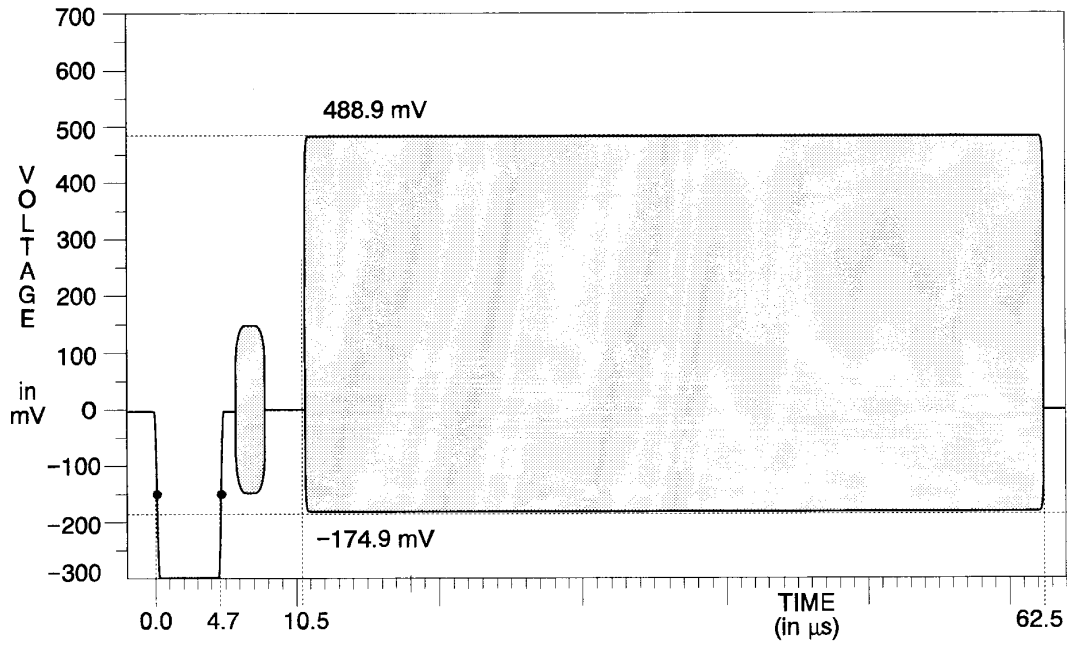

Figure 2-2: 75% red

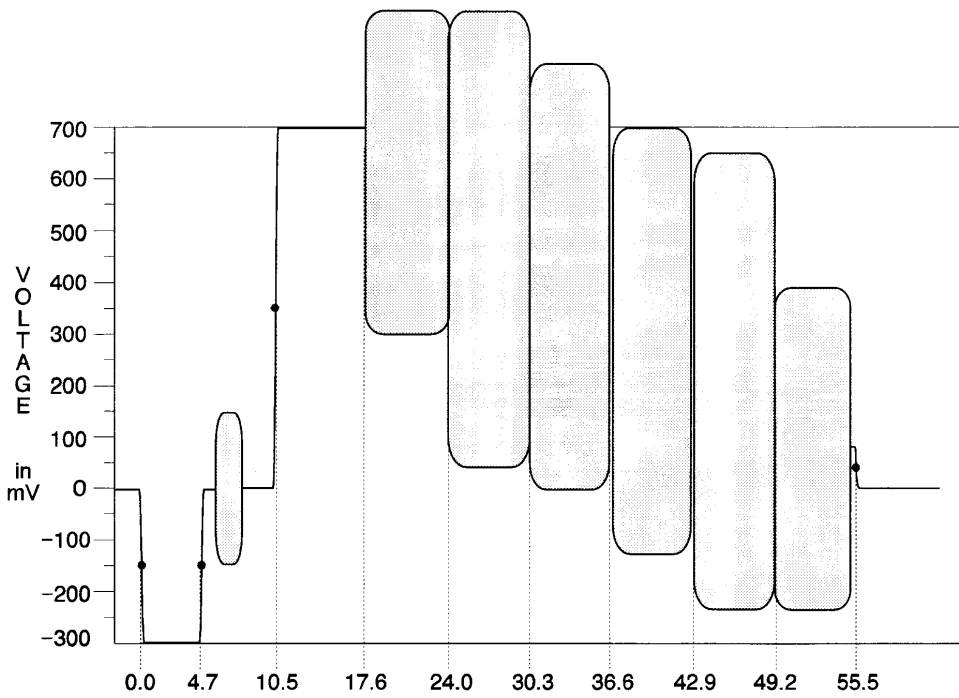

Figure 2-3: 100% color bars

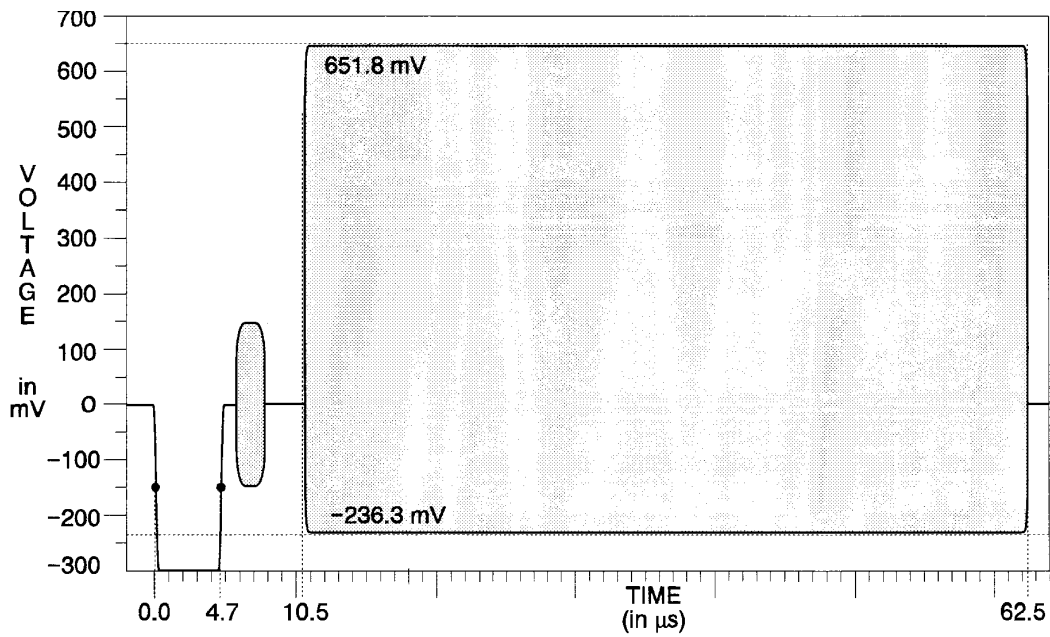

Figure 2-4: 100% red

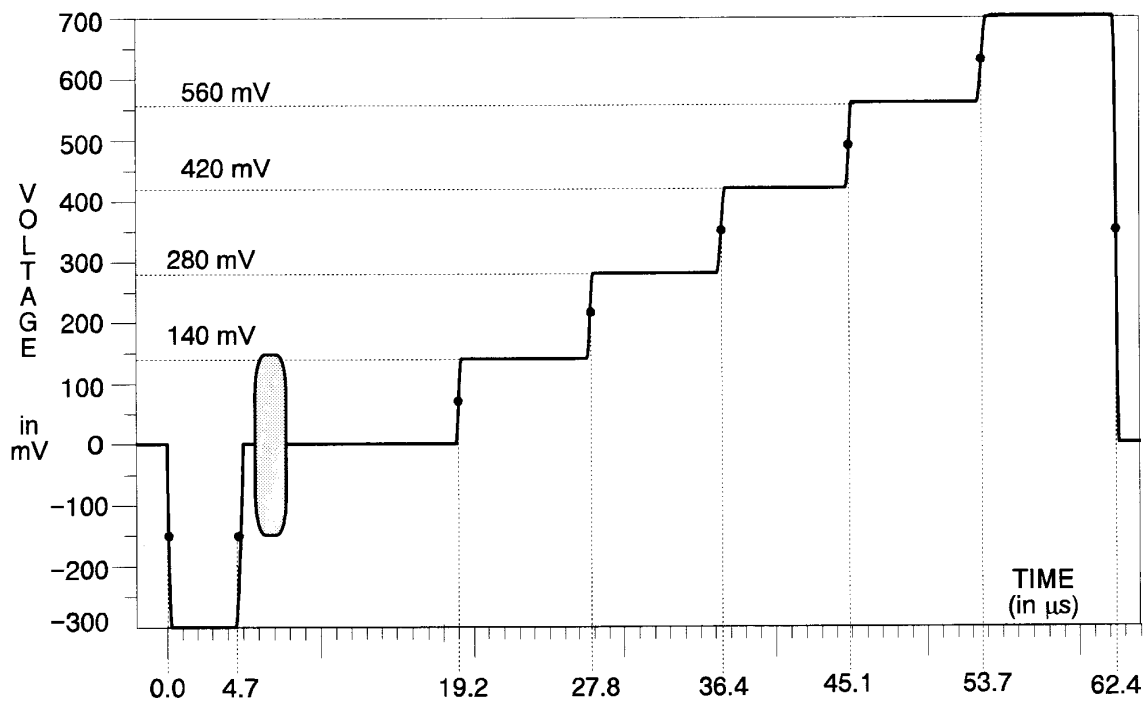

Figure 2-5: 5-step (gray scale)

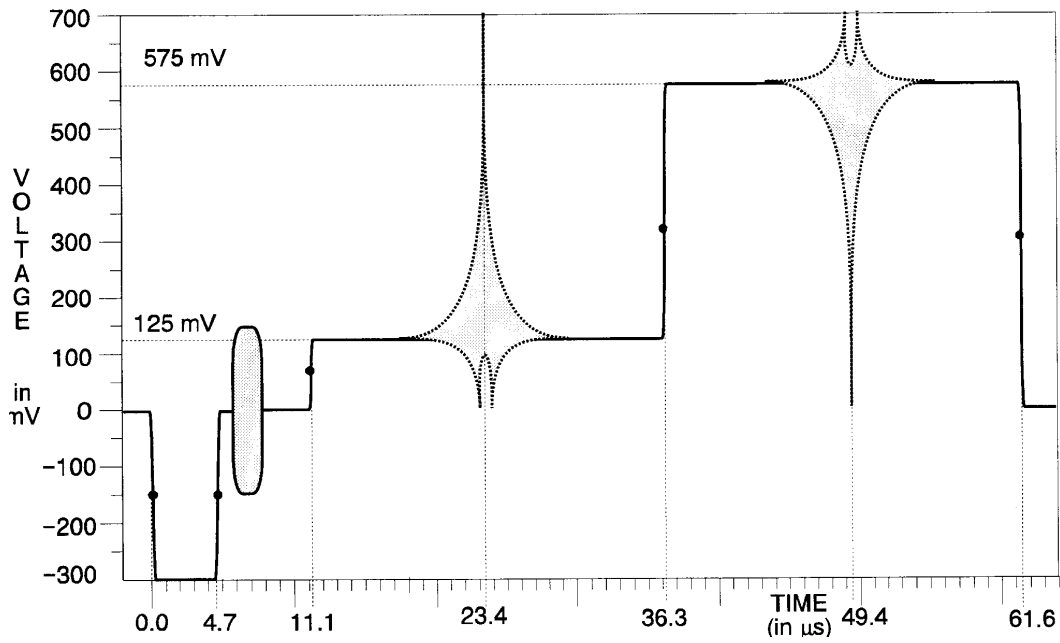

Figure 2-6: $\text{Sin}(x)/x$

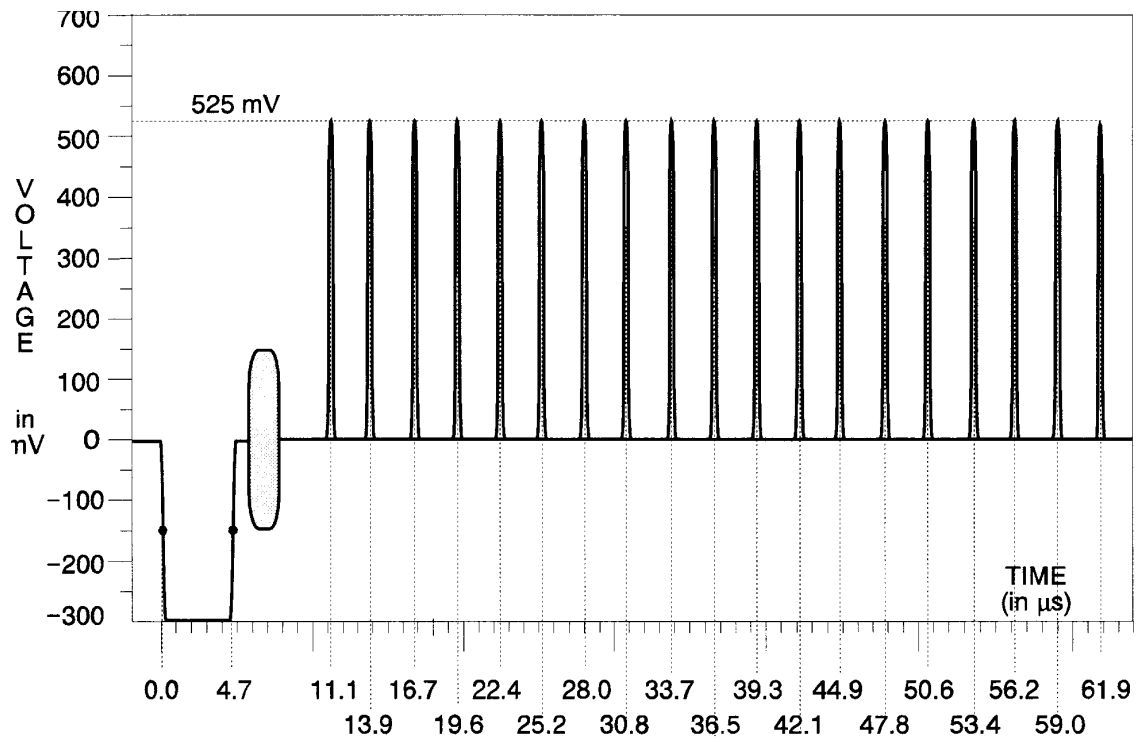

Figure 2-7: Convergence (vertical)

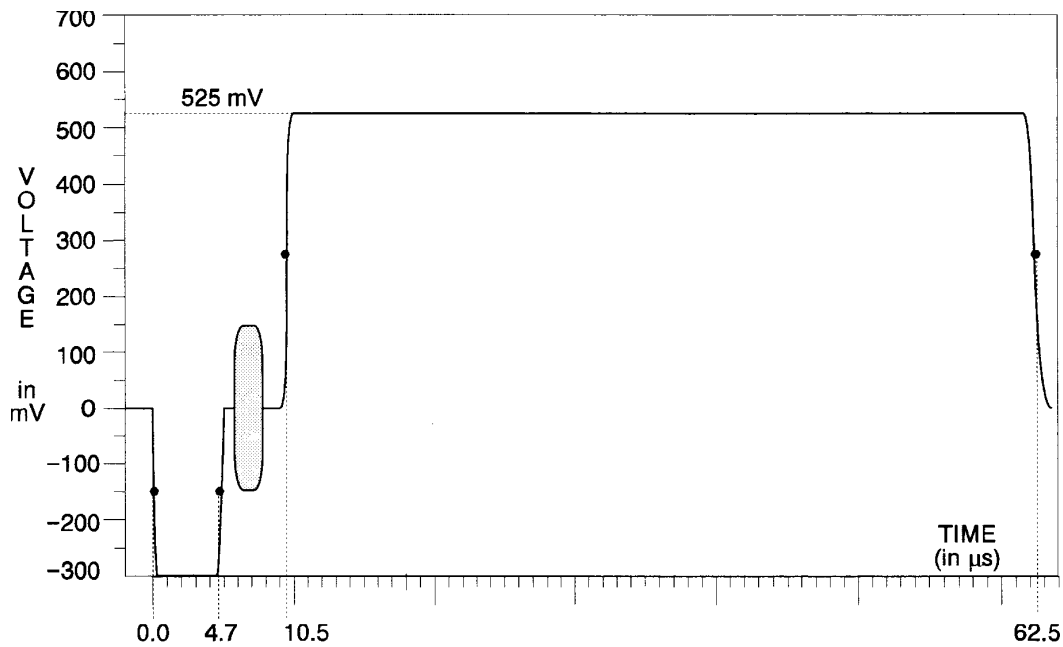

Figure 2-8: Convergence (horizontal)

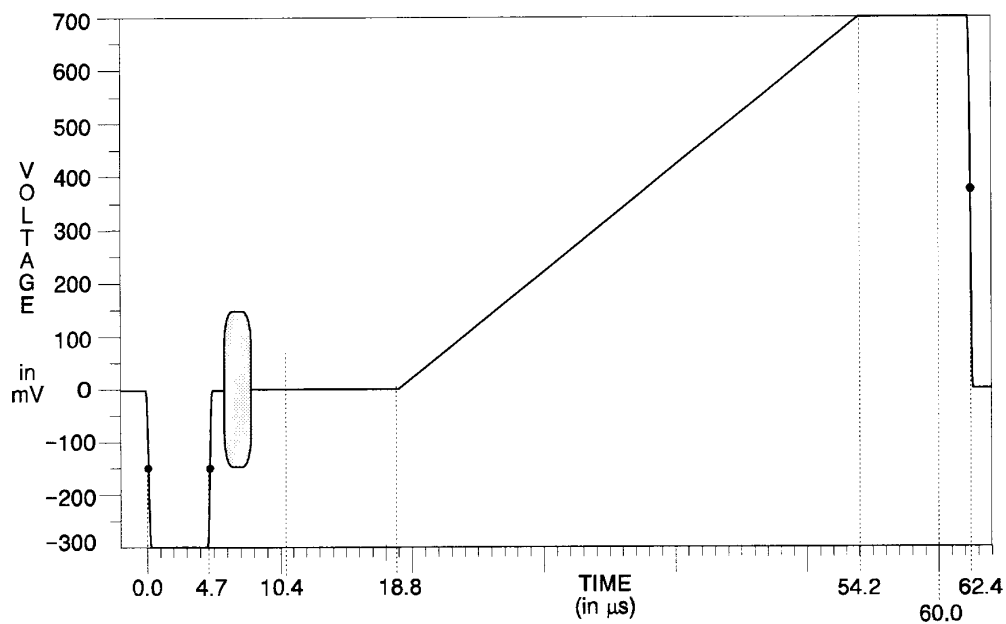

Figure 2-9: Ramp

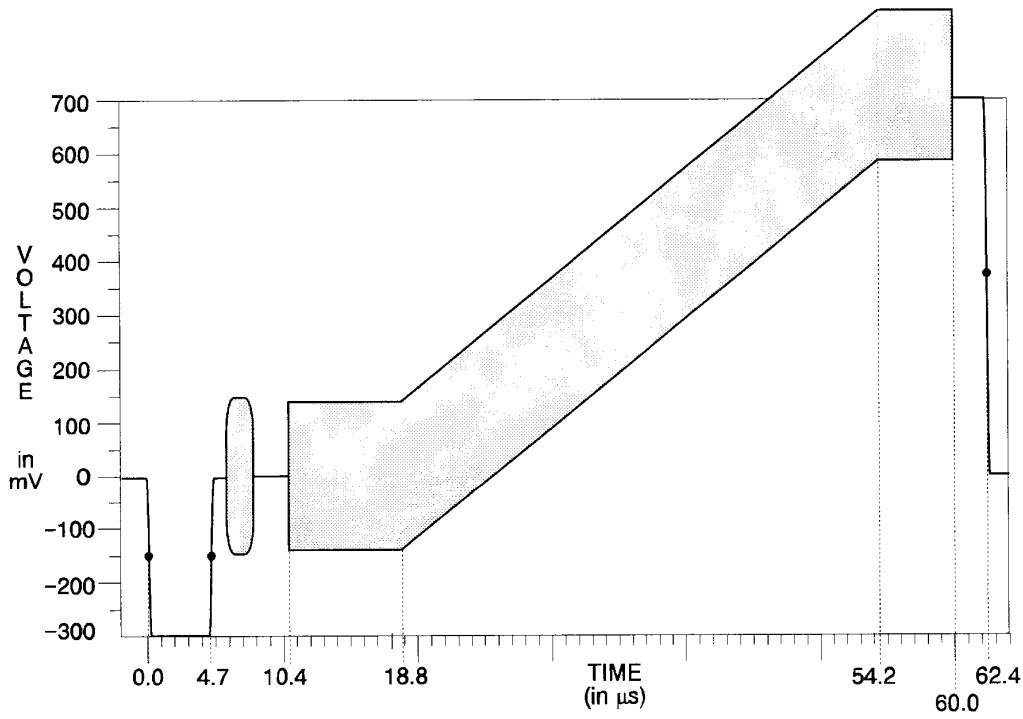

Figure 2-10: Modulated ramp

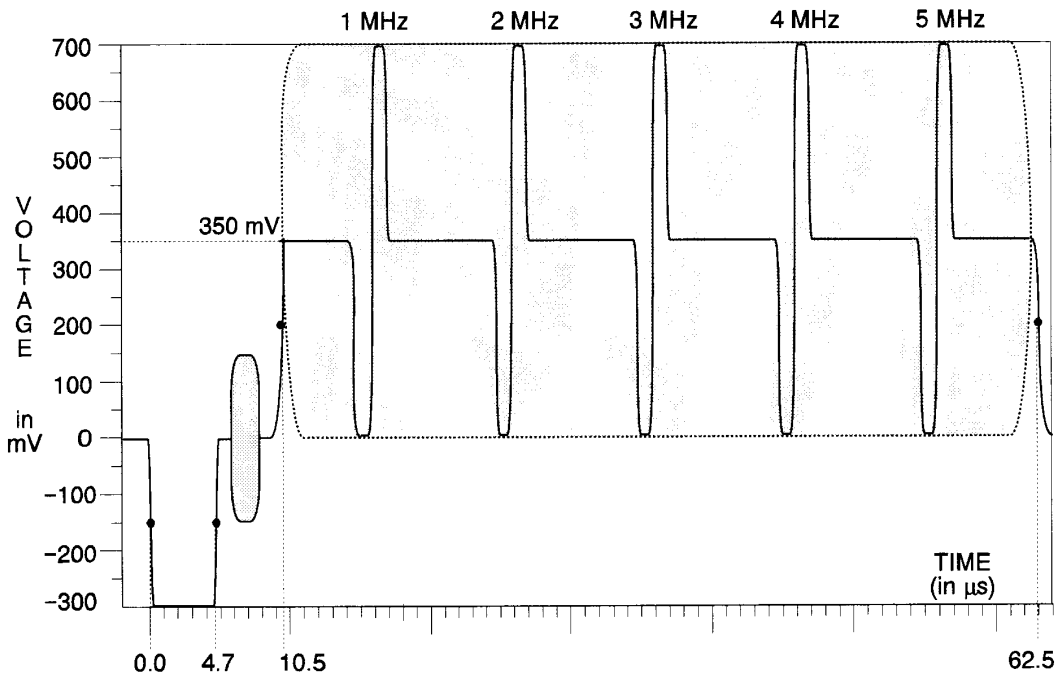

Figure 2-11: Line sweep

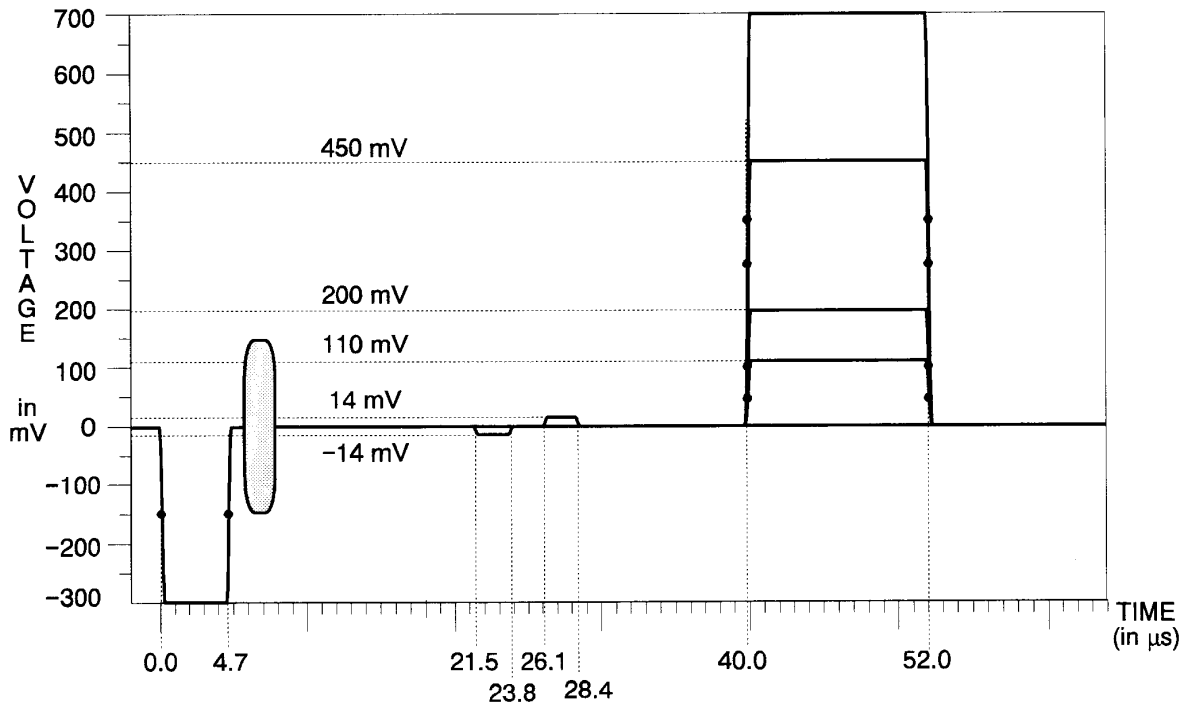

Figure 2-12: Pluge

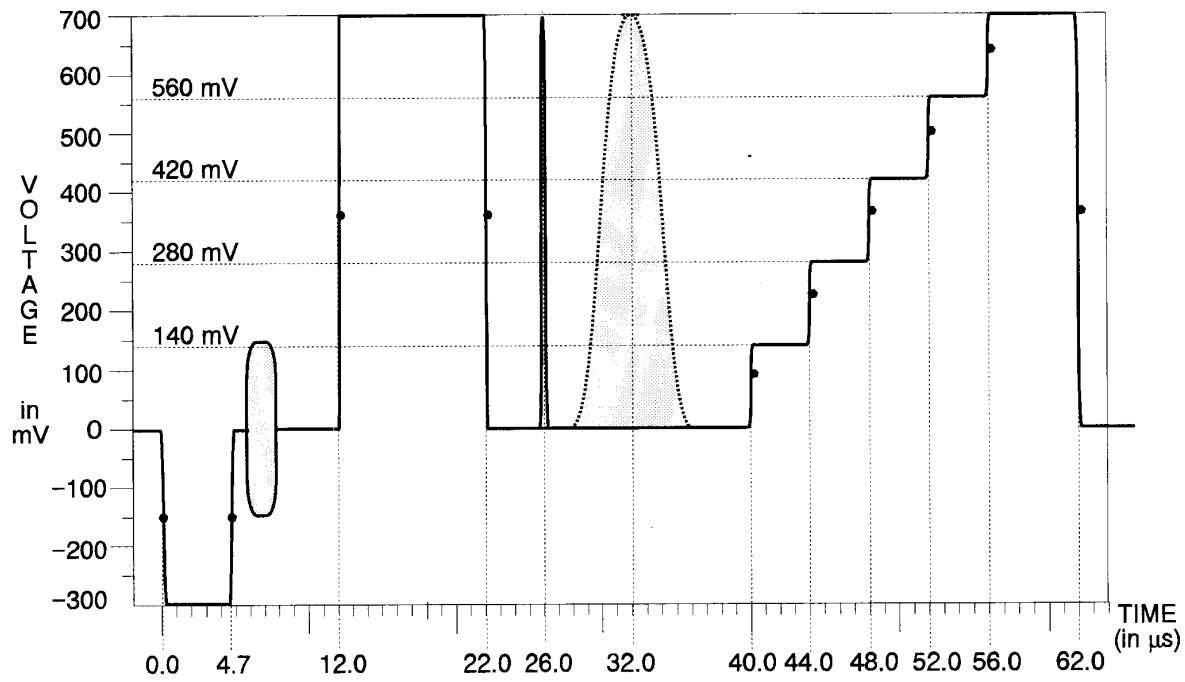

Figure 2-13: CCIR 17

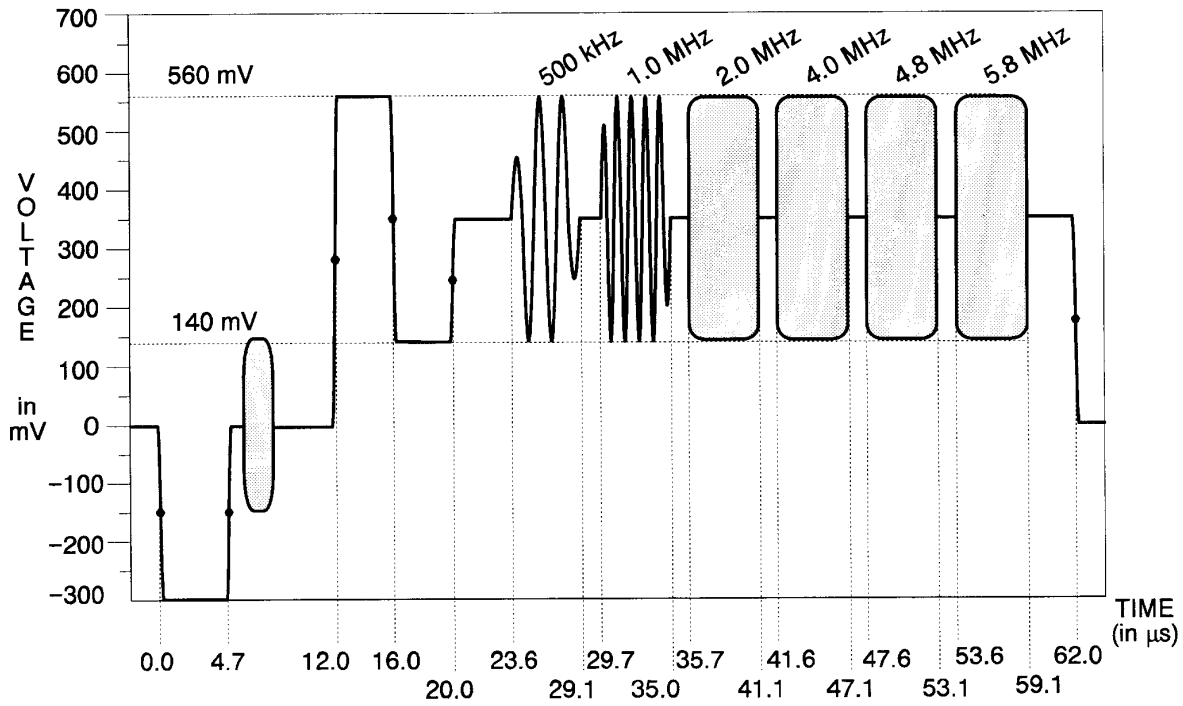

Figure 2-14: CCIR 18 (multiburst)

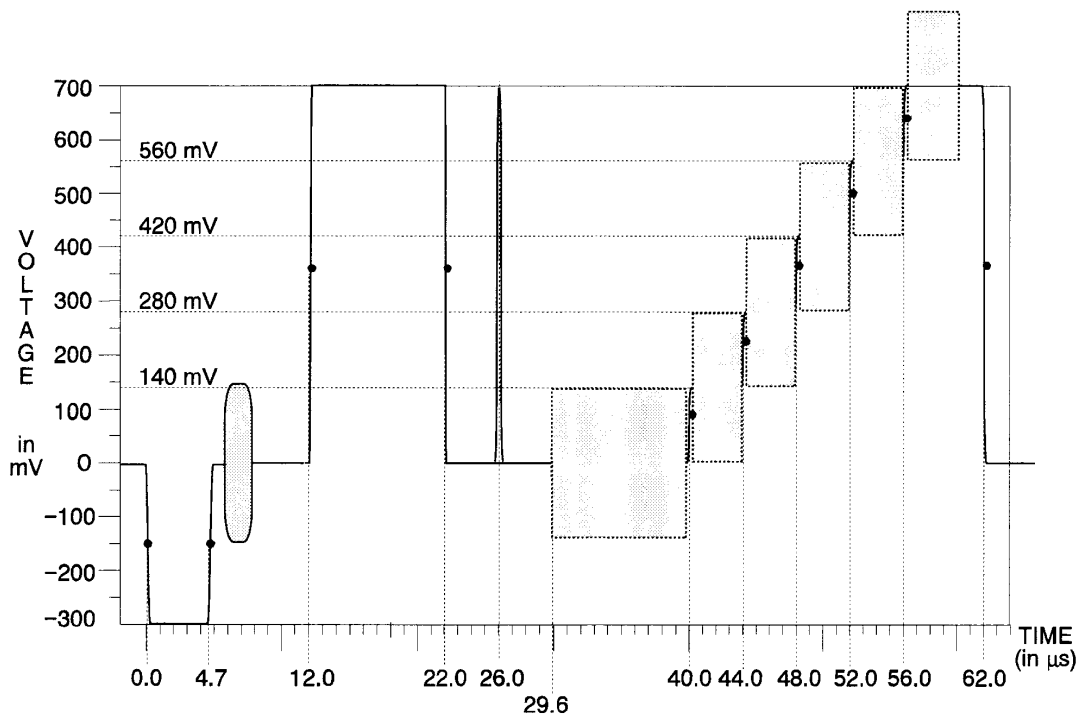

Figure 2-15: CCIR 330

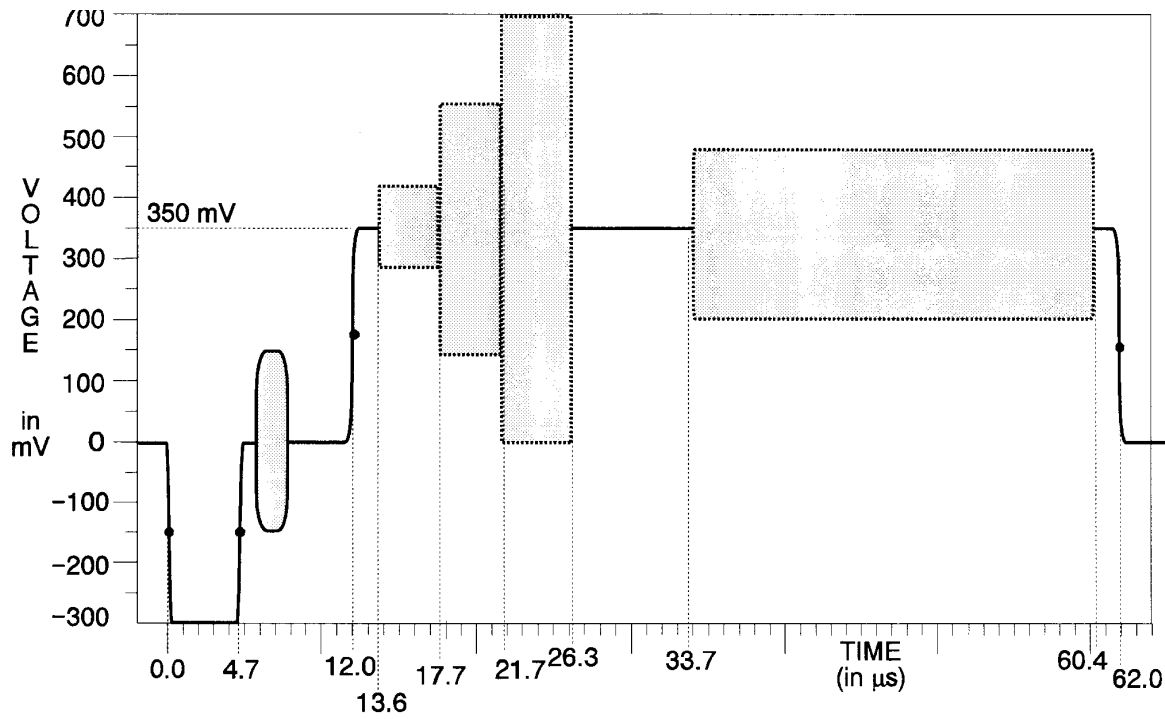

Figure 2-16: CCIR 331

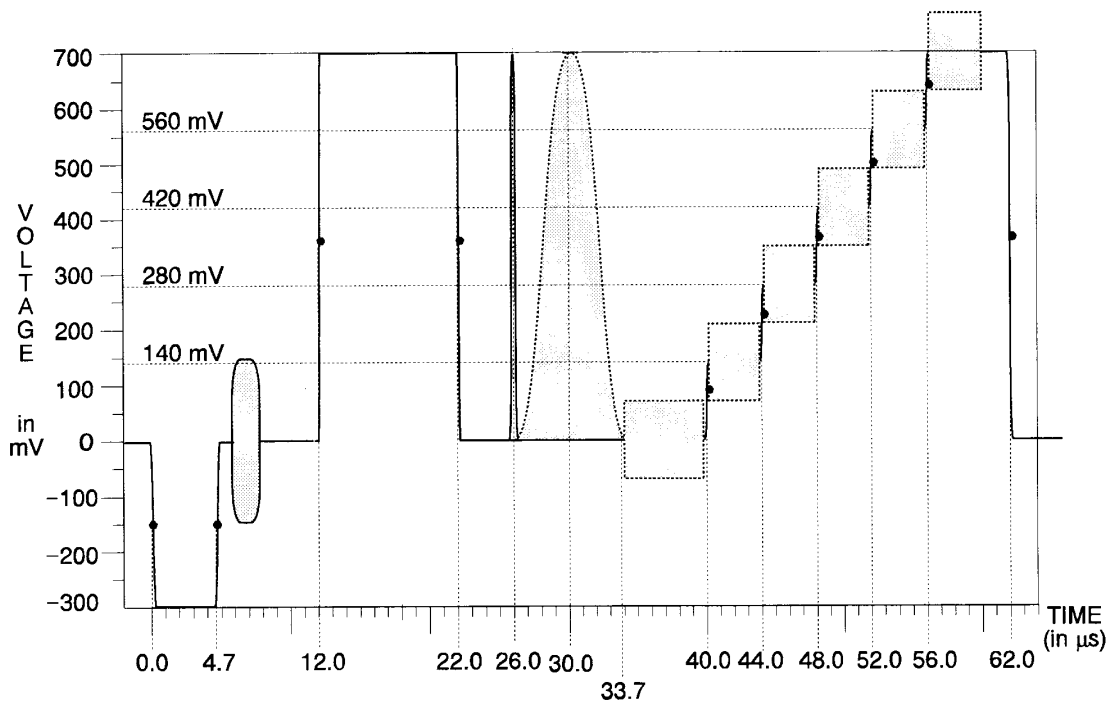

Figure 2-17: UK ITS 1

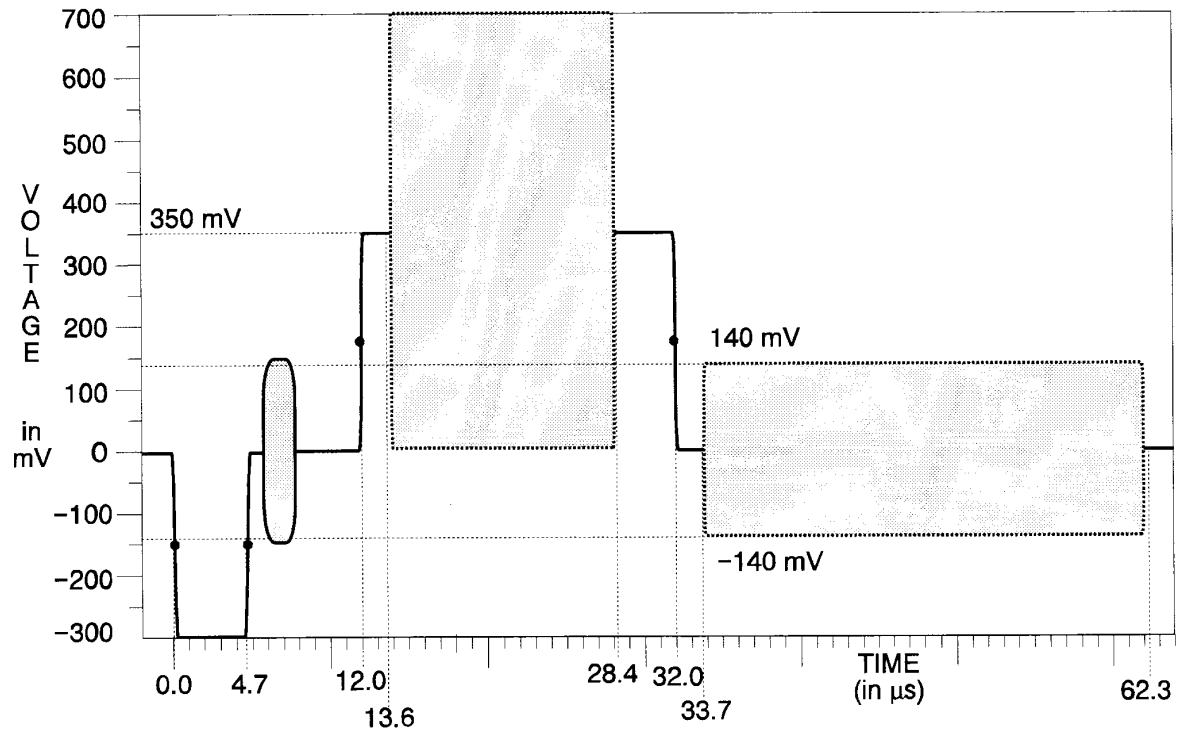

Figure 2-18: UK ITS 2

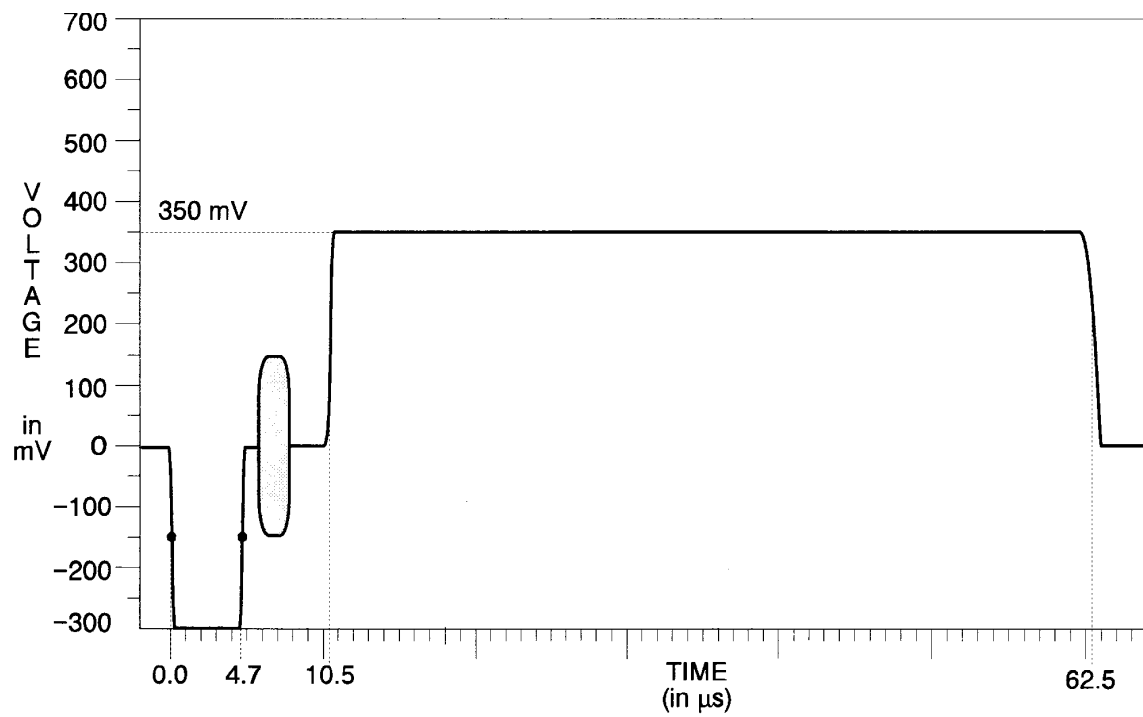

Figure 2-19: 50% field

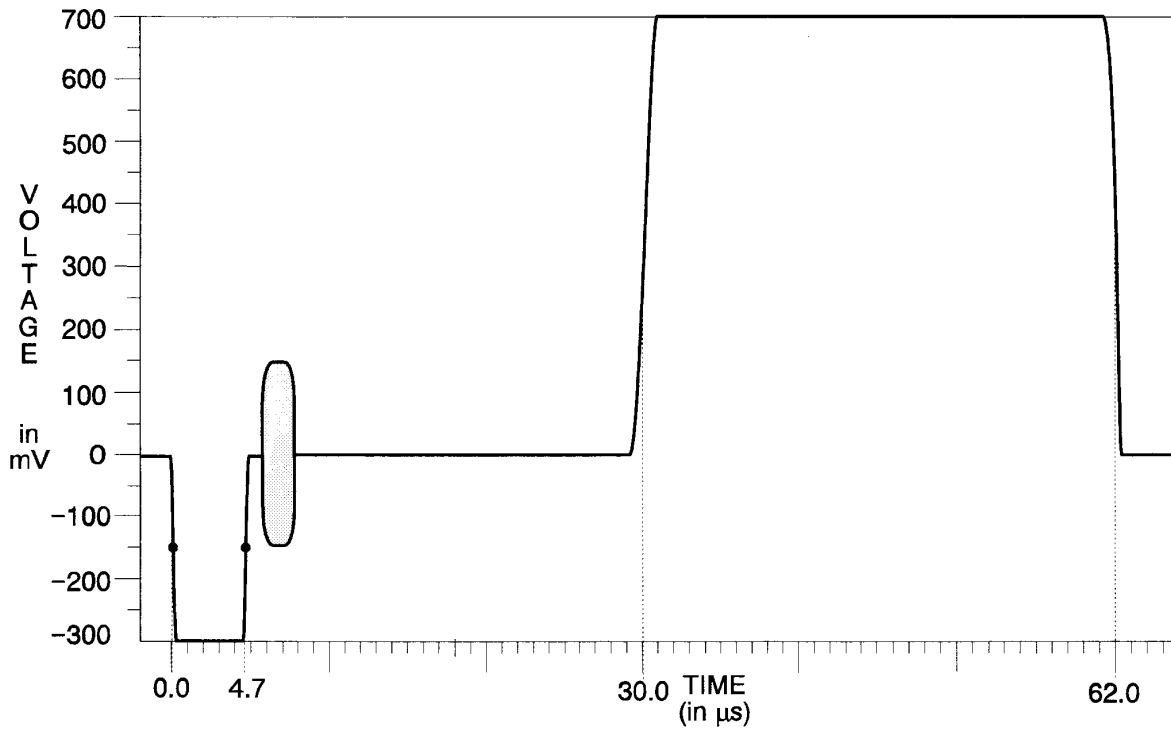

Figure 2-20: 15 kHz square wave

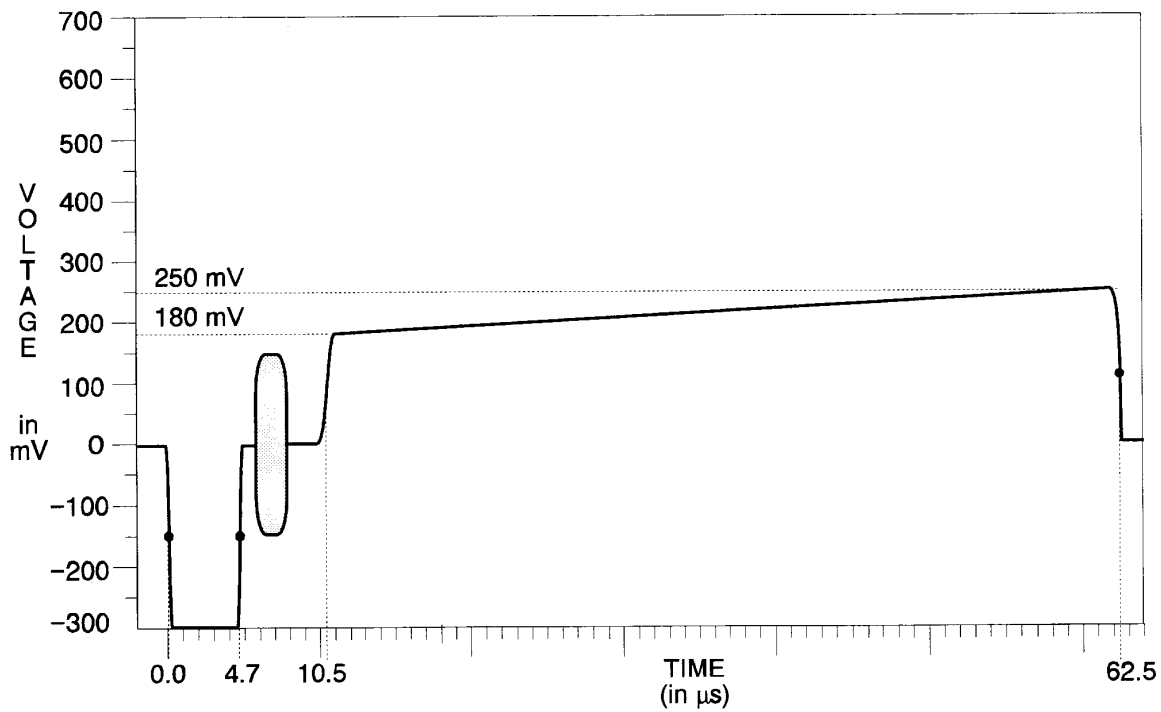

Figure 2-21: Shallow ramp

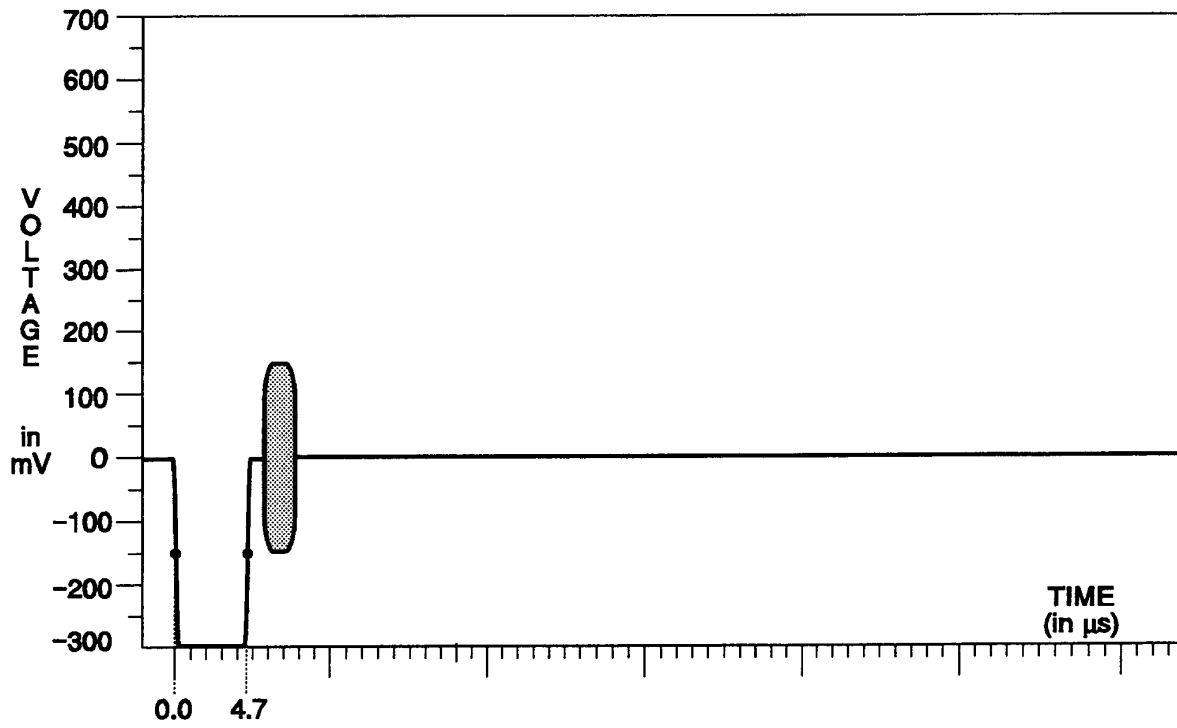

Figure 2-22: Black burst (Option 02)

WARNING

The following servicing instructions are for use only by qualified personnel. To avoid injury, do not perform any servicing other than that stated in the operating instructions unless you are qualified to do so. Refer to all safety summaries before performing any service.



Theory of Operation

Theory of Operation

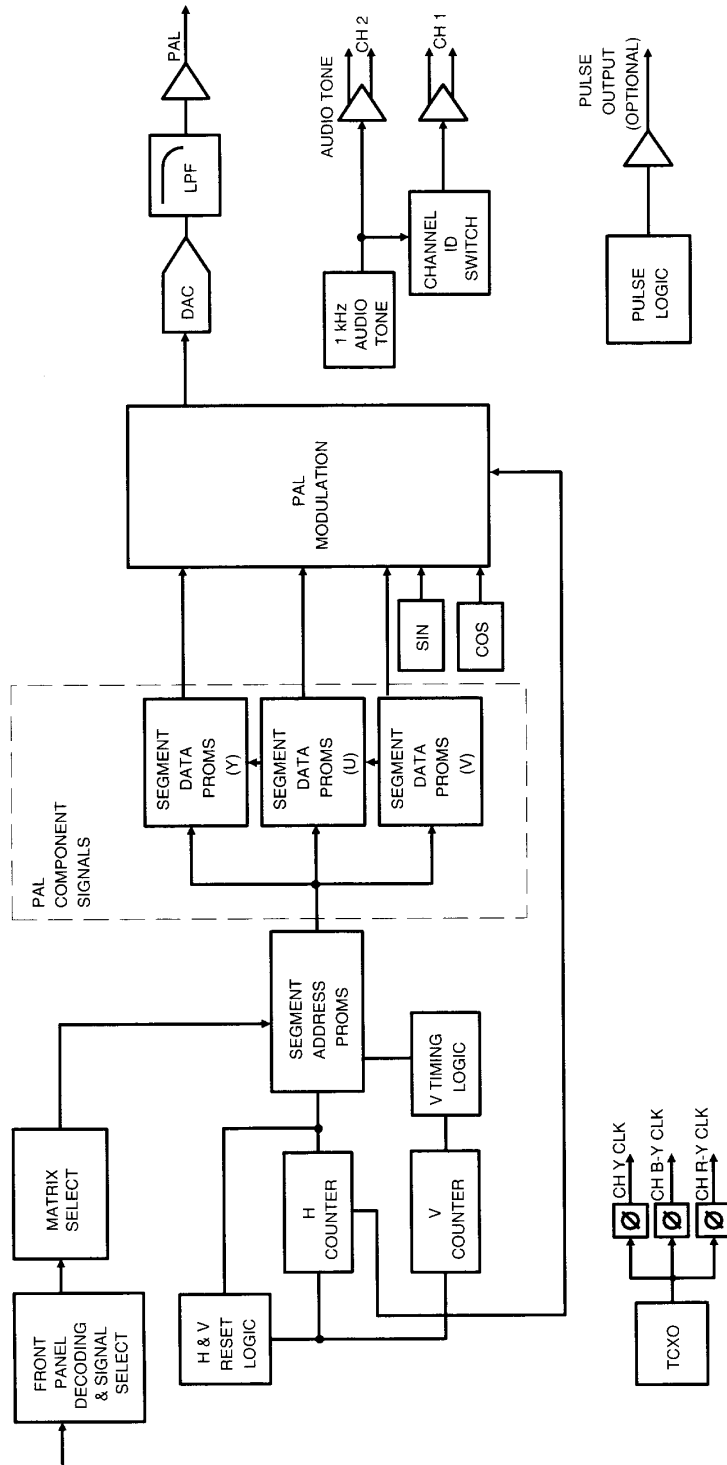

Figure 3-1: TSG 111 block diagram.

Front Panel <1>

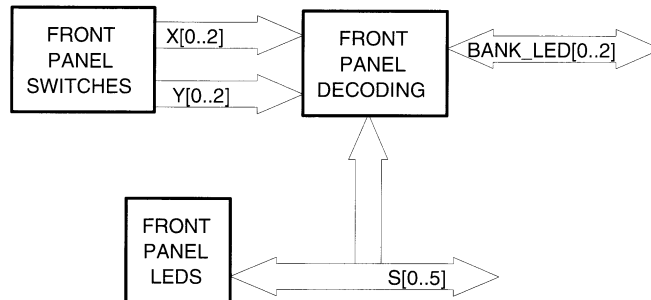

Figure 3-2: Front panel block diagram <1>

The front-panel switches (S201A through S209A) select which signals are available at the rear-panel BNCs and which LEDs are lit on the front panel. When one of the momentary contact switches closes, it sends a pulse to the encoder, U204, which translates it into signal KPAD[0..3]. EPROM U210 translates KPAD[0..3] into FMT[0..1] and K[0..2] for PROM U207.

U207 looks at the signal that is currently selected, S[0..5], along with the key selection information from U210, to determine the desired signal. The desired signal is output as S[0..5]. This signal is also translated in U209 to drive the LEDs in the push buttons, S202B through S209B. S[0..5] goes to U245 <2> on the Main board. U207 also generates BANK_LED[0..1] for U201 <2>. U201 then drives the row indicator LEDs (DS220 and DS221) with BANK_LED[1..2].

Digital Generation and Clock <2>

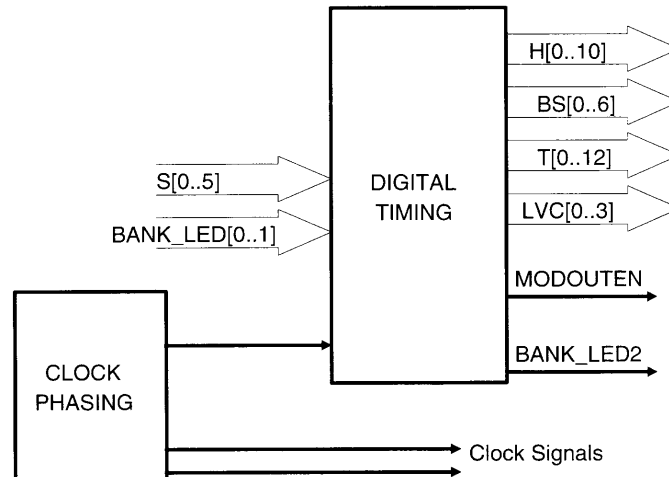

Figure 3–3: Digital generation and clock block diagram <2>

Clock Phasing

The clock for the instrument is a stable 17.734375 MHz crystal, Y1. The TTL level of this signal is converted to ECL levels at pin 5 of U106. One copy of this signal is fed to U108 and converted to TTL level (CHY2_CLK). This signal is the general-purpose clock used in the rest of the instrument. To assure that all clocks are in phase, the other copy of the signal is timed by an RLC network (R231, L71, and C263). It is then converted to TTL level by U108 pins 2 and 3. The resulting signal is CHY1_CLK which is used by the Y Channel DAC. This signal is then fed to U106 at pins 10 and 11. The resulting clock goes through an RLC network where the capacitor (C30) is used to adjust the SC/H phase. This signal then goes to the ECL-to-TTL converter, U108, and becomes CHBY_CLK. This clock is used by the output DAC.

Digital Timing

The Digital Timing circuit has several purposes: to control the vertical and horizontal timing, to request the correct signal (according to the timing information), and to control signal modulation.

The selected signal, from the front panel, is coded in S[0..5]. That signal is latched in U245 where it is combined with other information (F1L7 pulse on or off and diagnostic signals) and converted to DS[0..6] (data segment). DS[0..6] drives EPROM U202.

U202 contains a horizontal, bounce, and vertical counter in addition to a timing decoder and signal selection decoders. H[0..11] is the output of the horizontal counter. It drives the Signal Segment Address Memory <3> and clocks its latches. BS[0..6] is a decoded version of the signal selection from the front panel. It is a modification of the signal selected to incorporate the bounce signal

or a special signal required due to signal variations from line to line. For example, a convergence signal has several lines of one signal and then a white line. The same is true of any matrix signal.

The level of (MODOUTEN) determines whether or not the Modulator <4> is enabled. (MODOUTEN) is low for composite signals where the chrominance modulator, U222 <4>, output is enabled to drive to DAC (U31 <5>) inputs.

The other control signals tie together U202 with U201 which is predominantly a vertical counter followed by a decoder. 2FLDCLR makes sure that both vertical counters in U201 and U202 are locked together. VCNTREN enables U201's vertical counter.

EPROM U201 has several purposes: to derive the control signal for the row indicator on the front panel <1>, to generate the 25 Hz offset timing T[0..12] for the Lookup Table <4>, to disable burst at the end of the line for branch sequence, to provide the timing for the F1L7 white line, and to provide the vertical matrix timing LVC[0..3] for the Signal Segment Address Memory <3>.

Signal Memory <3>

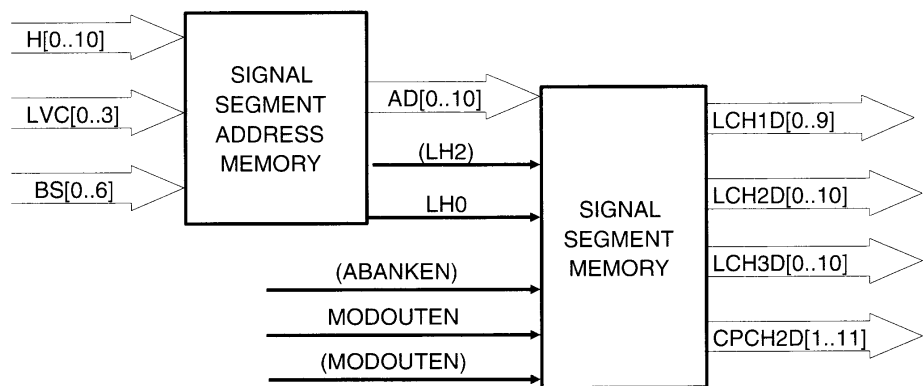

Figure 3-4: Signal Memory block diagram <3>

Signal Segment Address Memory

Signal information, LVC[0..3] and BS[0..6], along with the horizontal timing, H[3..10], are used by U104 and U102 to find the address for the signal segment required to create the selected signal. The output of these EPROMs is latched by U150 and U240. AD[0..10] is clocked out of these latches by a clock pulse derived from H2 (every eighth horizontal count of the main clock). The address goes to the Signal Segment Memory.

Signal Segment Memory

On the opposite clock count from when it was loaded into U150 and U240, the address is clocked into the Signal Segment Memory PROMs. U22 contains the

data for the first channel (Y). U24 contains the data for the second channel (U portion of chrominance). U26 contains the data for the third channel (V portion of chrominance). U28 contains the LSBs for all channels. All of these signals go to the Modulator, U222 <4>.

Digital Modulator and Lookup Table <4>

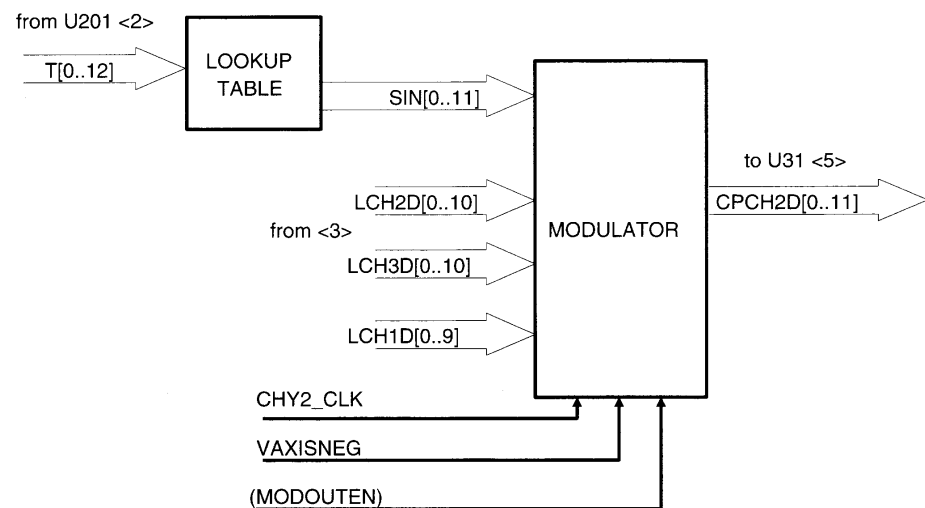

Figure 3–5: Digital modulator and lookup table block diagram <4>

Lookup Table U228 and U229 get their timing signal, T[0..12], from the Digital Timing circuit <2> and use that signal to derive the SIN[0..11] signal which is used by the modulator to determine how to modulate the signal. This includes the 25 Hz offset to the modulation.

Modulator U222 modulates the chrominance information for the PAL signal. When (MODOUTEN) is low, it combines LCH2D[0..10] and LCH3D[0..10], using SIN[0..11] as the modulation offset, into the signal for the second channel. It then combines the modulated chrominance information with the luminance information, LCH1d[0..9]. The output is of the modulator is CPCH2D[0..11] which drives output DAC <5>.

Analog Outputs <5>

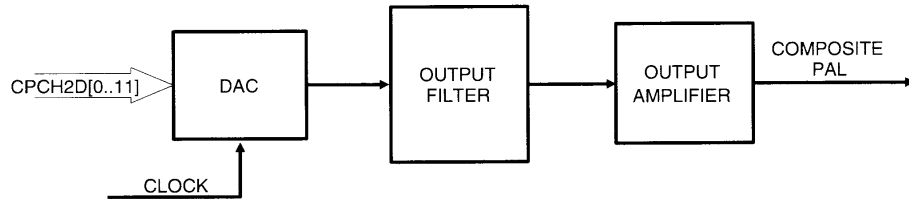

Figure 3-6: Analog Output block diagram <5>

DAC U31 is the DAC for the second channel. CH2D[0..11] from the Modulator <4> drives the DAC. The 12-bit DAC converts the signal into a voltage.

Output Filter FL2 is a low-pass filter that removes any high-frequency components caused by digitizing and makes the signal fit into the defined PAL bandwidth. The lowpassed signal is then ready to be amplified by the Output Amplifier.

Output Amplifier U30 is the same as U33, the Channel Y Output Amplifier. Its purpose is to amplify the signal so that it can drive 1 volt into 75. R50 controls the gain. R63 adjusts the DC offset. C47 adjusts the frequency response. The output is PAL1 and PAL2. They drive the two COMPOSITE outputs on the rear panel.

Audio Tone <7>

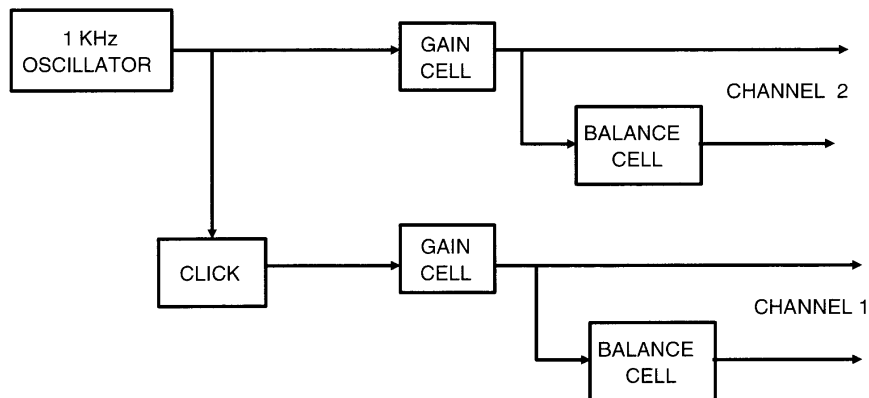

Figure 3-7: The Audio circuit <7>

- 1 kHz Oscillator** U40A is configured as a Wein oscillator, employing both positive and negative feedback. The positive feedback loop controls the frequency of oscillation, with C111, R107, R106, and C100 forming a bandpass filter tuned to 1 KHz. The negative feedback loop controls the gain to keep the circuit in oscillation.
- The circuit is designed to operate with a gain of three. This occurs when the positive and the negative feedback is balanced and produces an output signal of approximately 0.7 Vp-p. If the output amplitude starts to die off, the peak detector (U408 and associated components) reduces the drive to Q2, which increases the gain by increasing the current to the negative feedback loop.
- On the other hand, if the output amplitude increases, then the peak detector increases the drive to Q2, decreasing the current to the negative feedback loop, decreasing the gain.
- The output of the 1 KHz oscillator goes to the Gain Cells.
- Click Circuit** The Click circuit consists of a 555 timer, U43, its associated components, and an FET, Q1. The rate at which the timer sends out pulses is adjustable by R125 or it can be disabled by removing R126 from the circuit with J12. When a pulse is output from pin 3 it grounds the FET, which in turn pulls the channel 1 to ground and creates the “click” sound.
- Gain Cells** There are two gain cells, for channel 1 and channel 2. The gain cells consist of an op amp (U42A or U41A) with a negative feedback loop used to adjust the gain. R122 or R123 adjust the gain in the feedback loop by increasing or decreasing the feedback resistance. The output of the gain cell goes to pin 3 of the audio connectors and to the balance cell.
- Balance Cells** The balance cells are basically inverters that take a copy of the output of the gain cell and invert it to create the other channel for a balanced audio signal. The outputs go to pin 2 of the audio connectors.

Power Supply <8>

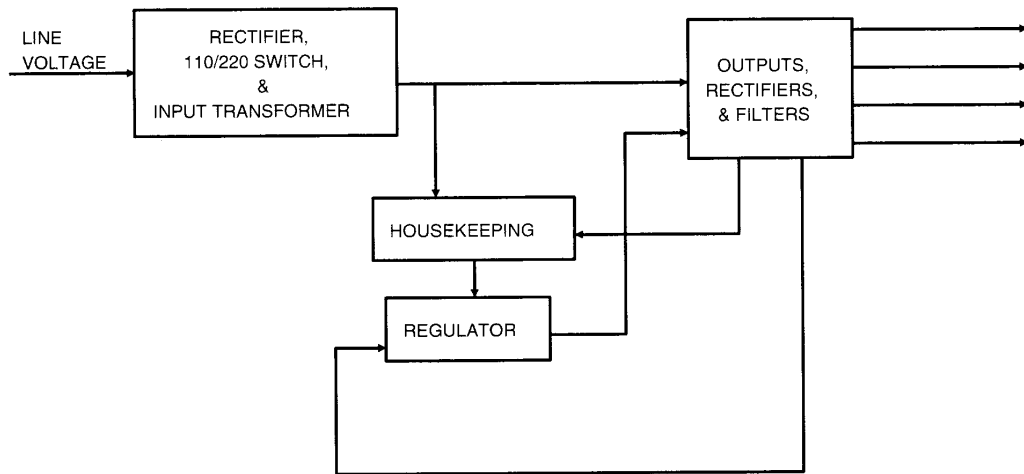

Figure 3-8: Power supply block diagram <8>

Rectifier and Input Transformer and 110/220 Switch

The input voltage can either be 110 V or 220 V. If it is 110V, P10 and P122 are in the circuit, which puts all of transformer T1's windings in the circuit. If the Input voltage is 220V then P11 is in the circuit, which removes half of T1's windings from the circuit. The available input voltage on the output side of T1 is then the same. The output from line transformer T1 is a relative low voltage of approximately 20 volts.

This voltage is then rectified by CR10, CR11, CR12, and CR13. The rectifiers convert the sine wave into positive going sine-shaped pulses. C183 smooths the pulses to approximately 16 volts with ripple.

Housekeeping

VR30 and Q30 make up the Housekeeping circuitry. Its purpose is to supply 11 V to the Regulator (U200) during power-up conditions and as an input buffer when the DC input is used.

After power up, the Housekeeping circuit is shut down. The voltage from CR85 goes up to 15V which shuts down Q30.

Regulator

U200 is a Pulse Width Modulator that is a current mode controller. It uses inputs from the primary circuit and from the +5 V output to vary the width of the pulse controls, Q100. This regulates the secondary voltages through variations of input voltage, output load, etc.

Current mode control works by allowing the current flowing in the primary to reach peak level that is set by the output of the +5 V output. The current in the primary is sensed by the R267 and C308 and applied to U200 at pin 3 as a voltage. At the start of the cycle, the oscillator within the Pulse Width Modulator

internal oscillator sets the internal flip-flop which turns on Q100. The primary current, and therefore the voltage to U200 pin 3, ramps up until the ISEN input level is high enough to trip the comparator. This resets the flip-flop, ending the drive pulse to Q100, and the energy stored in the transformer is transferred to the secondaries.

Line regulation, then, is a function of line voltage. As the line voltage varies, so will the primary current. An increase in line voltage causes an increase in primary current, so the slope of the ramp increases and the trip point is reached sooner. This results in a shorter pulse width. A decrease in line voltage causes a decrease in primary current, the slope of the ramp decreases and it takes longer to reach the trip point. However, the same peak current is reached in both cases, so the same amount of energy is transferred to the load. Line regulation is then achieved without having to wait for output voltage variations.

Power Inductor Operation (T2)

The heart of this power supply is T2, the power inductor.

Inductor T2 is initially uncharged (zero magnetic flux). Q100, acting as a switch, is turned on by the base drive from the regulator (U200). The polarity of this voltage is such that the voltage induced in the secondary will reverse bias their respective diodes (note the polarity dots). In this way, there is no current flowing in the secondaries while it is flowing in the primary. C303 and R262 are a snubber circuit used to reduce noise.

The primary current builds a linear ramp, storing the energy in T2 according to the relationship:

$$E = 1/2 Li^2$$

where L is the primary inductance and i is the current flowing through it.

The current path is broken when Q100 is switched off, so current stops flowing in the primary. The flyback action of T2 then causes the voltage in the secondaries to linearly ramp down to zero as the energy which was stored in T2's primary is delivered to the load, charging its own capacitors.

When all of the energy which was stored in T2 during the first half of the cycle is delivered to the load, the current in the secondaries is zero, and the diodes turn off. There is no current flowing in either the primaries or the secondaries until Q100 is turned on to start the next cycle. As there is not a continuous flow of energy in T2, this is called a discontinuous flyback operation.

Load regulation is provided by sensing the +5 V supply with a resistor divider, R264 and R265. When +5 V goes too high, U200 narrows the pulse width. This reduces the amount of energy stored in T2, and therefore the amount of energy transferred to the load, so the +5 V goes down. Inversely, when the +5 V is too low, the pulse width is increased, increasing the amount of energy stored in T2 and then transferred to the load, so the voltage goes up.

Outputs, Rectifiers, and Filters

There are four separate circuits in the output: +5 V, -5 V, +12 V, and -12 V. They all work in a similar manner.

During the first half of the cycle, when Q100 is shut off, the flyback action reverses the polarities of the secondary and the diodes are forward-biased. This allows the energy in T2 to charge up the capacitors in the secondaries. The +5 V and the -5 V supplies use LC filters to further smooth the voltage and eliminate most of the ripple.

The +12 and -12 V supplies actually start as +15 and -15 V, at the transformer. Then they are filtered and applied to linear regulators, U212 and U50, which provide clean +12 V and -12 V outputs, respectively.



Performance Verification

Performance Verification

This section consists of checklists and detailed procedures to use in verifying performance parameters.

The order of these procedures has been chosen to minimize changes in equipment setup. Performance parameters may be checked in any order. However, because many adjustment steps are interactive, care must be taken when adjusting individual parameters to ensure that all others remain within specification.

Equipment List

Table 4–1 is a list of equipment required for the Performance Check in this section and the Adjustment Procedure in the next section. Alternate equipment may be used for the Performance Check, but it is not recommended for the Adjustment Procedure. Use of inadequate equipment may result in faulty measurements or adjustment.

Table 4–1: Performance verification equipment list

Equipment	Comments
PAL video measurement set For the performance check only, the following equipment may be used in place of the 1781.	For measuring and displaying field-rate and line-rate waveforms, differential phase and gain, and SC/H phase. Example: 1781 Video Measurement Set.
PAL waveform monitor	For displaying and measuring field-rate and line-rate waveforms. Example: Tektronix 1481 Mod W5F.
PAL vectorscope	With specific modes for measuring differential phase and gain. Example: Tektronix 521A.
Video Amplitude Calibration fixture (VAC)	Provides a chopped voltage reference accurate to 0.05% from 0 to 1V in 0.1 mV increments (used with the waveform monitor). Example: Tektronix part number 067-0916-00; plugs into a Tektronix TM 503 Power Mainframe.
Frequency counter	Must be accurate to within 2.5 Hz out of 5 MHz. Example: Tektronix DC 501, Opt 01; plugs into a TM 503 Power Mainframe.
Distortion analyzer	Must test power output over 0 to 8 dBm and be capable of detecting THD of 0.01% or less. Example: Tektronix AA501.
Audio amplifier	600Ω impedance.

Table 4–1: Performance verification equipment list (cont.)

Equipment	Comments
BNC coax cables	75 Ω impedance. Example: Tektronix part number 012-0074-00.
End-line termination	75 Ω termination equipped with a BNC connector. Example: Tektronix part number 011-0102-00.
Feed-through termination	75 Ω termination equipped with BNC connectors. Example: Tektronix part number 011-0103-00.
Audio connector-to-triple banana cable	Example: ITT Pamona Electronics, Model 4953-J-36. Must be configured to match the TSG 111 audio output. Pin 1, shield; pin 2, +; pin 3, -.

Performance Verification Checklist

Table 4–2 contains a checklist for the oscillator frequency, PAL test signal output, and audio output verification procedures described in the next section.

Table 4–2: Performance verification summary

No.	Procedure	Results
1	Subcarrier oscillator frequency	17.734375 MHz \pm 40 Hz (\pm 20 Hz if Option 10 is installed)
2	DC level	
3	Sync amplitude	
4	Burst amplitude	
5	5-step staircase linearity	\leq 1%
6	Luminance amplitude accuracy	\pm 1%
7	Chrominance amplitude	\pm 1%
8	Chrominance-to-luminance gain	\pm 1%, delay \leq 10 ns
9	Ringling	\leq 1% peak
10	Sync rise and fall times	
11	Sync timing	H sync and vertical serrations; equalizing pulses
12	Line blanking interval	12.0 μ s \pm 0.15 μ s
13	Frequency response	\pm 2% to 6 MHz
14	Differential phase and gain	\leq 0.3 $^\circ$ and \leq 0.3%
15	SC/H accuracy	0 $^\circ$ \pm 5 $^\circ$
16	Total harmonic distortion	\leq 0.5%

Performance Verification Procedures

This section contains the verification procedures.

Oscillator Frequency See Figure 4–1 for the oscillator frequency verification setup.

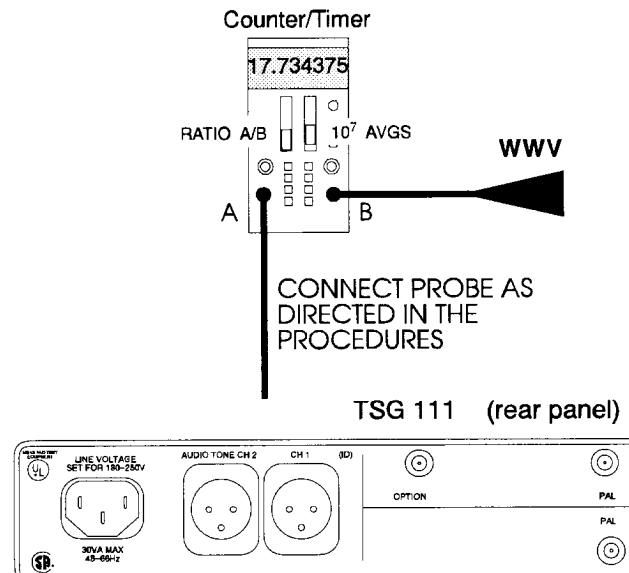

Figure 4–1: Setup to verify crystal frequency

Oscillator Frequency

NOTE. After initial delivery or long storage, allow a two-hour warm up to re-age the crystal. Thereafter, 30 minutes warm up is sufficient.

1. Connect the equipment as shown in Figure 4–1, attaching the probe to J108 in the 1–2 position.
2. Set the frequency counter to count at a rate using ratio A/B.
3. CHECK – that the measured oscillator frequency is 17.734375 MHz \pm 40 Hz (\pm 20 Hz if Option 10 is installed) at room temperature.

Table 4–3 lists the suggested Tektronix 1781 setup for the remaining TSG 111 Performance Checks, while Figure 4–2 shows the basic setup.

Table 4-3: Basic setup for the 1781

Configure	
Coupling	DC
Vector Grat	INT
WFM Grat	INT
ABS Units	mV
Vector Readout	ON
WFM Readout	ON
Front panel	
Left Display	VECT
Right Display	WFM
WFM Horizontal	ONE/LINE
REF	INT
Filter	FLAT
Waveform Gain	OFF

TSG 111 (rear panel)

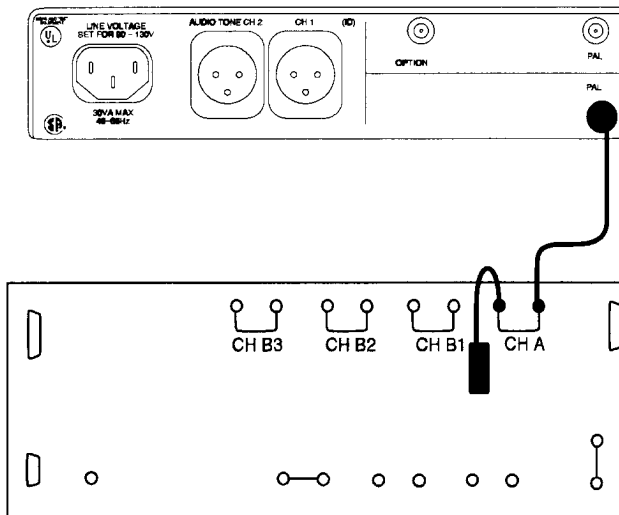

1781 WAVEFORM MONITOR/VECTORSCOPE (rear panel)

Figure 4-2: Basic setup for Performance Checks

PAL Test Signal

Following are procedures to measure the PAL test signal.

DC Level

1. Connect the equipment as shown in Figure 4–2.
2. Display CH A on the waveform monitor.
3. Select the 5-Step (grayscale) signal from the TSG 111.
4. Confirm that any monitor or oscilloscope DC-restorer feature is off.
5. Toggle the display between DC coupled and ground reference.
6. CHECK – that the DC level is $0\text{ V} \pm 50\text{ mV}$.

Sync Amplitude

1. Connect the test equipment as shown in Figure 4–2.
2. Display CH A on the waveform monitor.
3. Select the 5-Step (grayscale) signal from the TSG 111.
4. With the WFM + CAL function of the measurement set match the DC level of the lower waveform to the sync tip of the upper waveform.
5. CHECK – that the sync amplitude is $300\text{ mV} \pm 30\text{ mV}$.

Burst Amplitude

1. Connect the test equipment as shown in Figure 4–2.
2. Display CH A on the waveform monitor.
3. If necessary, adjust the measurement set to match the top of the lower burst to the bottom of the upper burst.
4. CHECK – for a burst amplitude of $300\text{ mV} \pm 6\text{ mV}$.

5-Step Staircase Linearity

1. Connect the test equipment as shown in Figure 4–2.
2. Display CH A on the waveform monitor.
3. With the 5-Step (grayscale) signal selected, set the test equipment to view the signal through the differentiated step filter.
4. CHECK – that the difference between the highest and lowest spikes (differentiated steps) is $<1\%$.

Luminance Amplitude Accuracy

1. Connect the test equipment as shown in Figure 4–2.
2. Display CH A on the waveform monitor.
3. Put the waveform monitor in WFM+CAL mode.
4. Set the test equipment to match the top of the lower 5-Step waveform with the DC level of the upper waveform.
5. CHECK – that the 5-Step (grayscale) amplitude is $700 \text{ mV} \pm 7 \text{ mV}$.

Chrominance Amplitude

1. Connect the test equipment as shown in Figure 4–2. Keep the waveform monitor in WFM + CAL.
2. Display CH A on the waveform monitor.
3. Select the UK ITS2 signal from the TSG 111.
4. If necessary, adjust the test equipment to match the top of the lower waveform with the blanking level of the upper.
5. CHECK – that the amplitude of the first (chrominance) half of the signal is $700 \text{ mV}_{\text{p-p}} \pm 7 \text{ mV}$.

Chrominance-to-Luminance Gain and Delay

1. Connect the test equipment as shown in Figure 4–2.
2. Display CH A on the waveform monitor.
3. Select the CCIR 17 signal from the TSG 111.
4. Set the waveform monitor to view the bottom of the 20T modulated pulse.
5. Use the Chroma/Luma measurement mode of the Tektronix 1781 to measure both C/Y delay and gain.
6. CHECK – that the delay is $<5 \text{ ns}$ and the gain is $<1\%$.

Ringling

1. Connect the test equipment as shown in Figure 4–2.
2. With the TSG 111's CCIR 17 still selected, set the waveform monitor to display the bottom of the 2T pulse.

3. CHECK – with voltage cursors or graticule that ringing is $<1\%$ (7-mV peak).

Sync Rise Times

1. Connect the test equipment as shown in Figure 4–2.
2. Display CH A on the waveform monitor.
3. Set the waveform monitor to display the sync on any TSG 111 test signal.
4. Identify the 10% and 90% points of the sync transitions. This can be done with voltage cursors or graticule, and may be aided by using variable gain to normalize the sync to 1000 mV.
5. CHECK – that rise and fall times between 10% and 90% are $250\text{ ns} \pm 25\text{ ns}$, using the timing cursors or graticule.

Sync Timing

1. Connect the test equipment as shown in Figure 4–2.
2. Display CH A on the waveform monitor.
3. CHECK – that horizontal sync duration between 50% points is $4.7\text{ }\mu\text{s} \pm 50\text{ ns}$.
4. Set the waveform monitor to display the serrations and equalizing pulses in the vertical interval.
5. CHECK – that the half-amplitude duration of the vertical serrations is $4.7\text{ }\mu\text{s} \pm 50\text{ ns}$.
6. CHECK – that the half-amplitude duration of the equalizing pulses is $2.35\text{ }\mu\text{s} \pm 50\text{ ns}$.

Line Blanking Interval

1. Connect the test equipment as shown in Figure 4–2.
2. Display CH A on the waveform monitor.
3. Select the Sweep signal from the TSG 111.
4. Set the waveform monitor to display horizontal blanking.
5. CHECK – that the horizontal blanking interval is $12.0\text{ }\mu\text{s} \pm 0.15\text{ }\mu\text{s}$ between the 350 mV points of the signal.

Frequency Response

1. Connect the test equipment as shown in Figure 4–2.
2. Display CH A on the waveform monitor.
3. Select the Line Sweep signal from the TSG 111.
4. CHECK – that the sweep is flat and equal in amplitude within 2% to 5 MHz.

Differential Phase and Gain

1. Connect the test equipment as shown in Figure 4–2.
2. Display CH A on the waveform monitor.
3. Select the Mod Ramp signal from the TSG 111.
4. Set the vectorscope to measure differential phase. (Use the double trace method, if possible.)
5. CHECK – for differential phase of $\leq 0.8^\circ$.
6. Set the test equipment to measure differential gain. (Again, use a double trace, if possible.)
7. CHECK – that the differential gain of the modulated ramp is $\leq 0.8\%$.

SC/H Phase

1. Connect the test equipment as shown in Figure 4–2.
2. Display CH A on the waveform monitor.

NOTE. Accurate SC/H measurements may be difficult without test equipment having modes intended for that purpose. The SC/H phase error in TSG 111 test signals is typically less than 1° .

3. Select any test signal from the TSG 111.
4. Confirm that the measurement set is internally referenced and set it to display the SC/H phase of the signal.
5. CHECK – that the SC/H phase error is $< 5^\circ$.

Figure 4–3 shows the setup to measure THD.

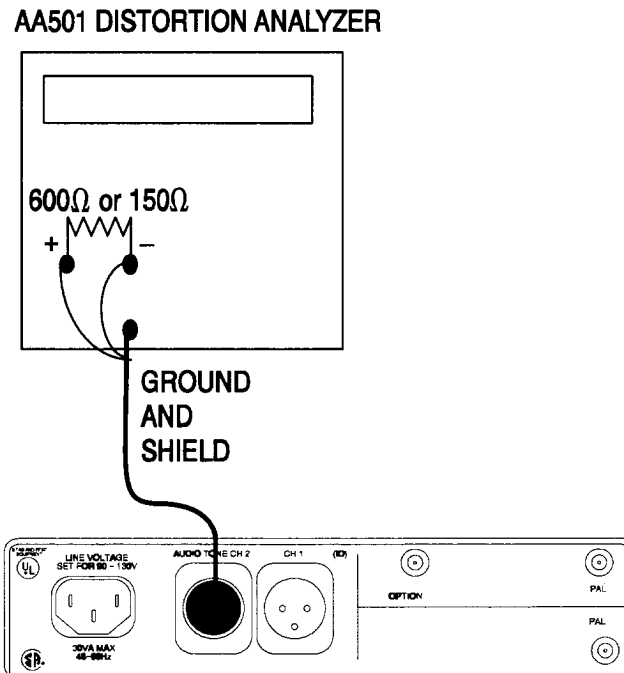

Figure 4–3: Setup to measure total harmonic distortion (THD)

Audio Output Following is the procedure to measure THD.

Total Harmonic Distortion

1. Disable the CH 1 ID click by moving jumper J12 to pins 2 and 3.
2. Connect the equipment as shown in Figure 4–3, placing a 600Ω resistor across the analyzer's + and – terminals (to represent the system load).
3. Set the distortion analyzer to measure THD.
4. CHECK – that the THD on CH 1 is $\leq 0.5\%$.
5. Return jumper J12 to pins 1 and 2.
6. Move the cable at the TSG 111 from audio CH 1 to audio CH 2.
7. CHECK – that the THD on CH 2 is $\leq 0.5\%$.



Adjustment Procedure

Adjustment Procedures

Following is the checklist for the adjustment procedures described in the next section.

Adjustment Procedure Checklist

No.	Procedure	Adjustment	Notes
1	Oscillator frequency		
2	Audio output amplitude	R122 (Ch 2), R123 (Ch 1)	
3	Audio ID Click Frequency	R126	
4	Gain and DC level	R23	The parts calibrated in step 4 may not be installed in all TSG 111s. If these parts are not installed, simply skip this procedure.
5	PAL (Sin(x))/x Compensation	C21 ((Sin(x))/x Compensation)	
6	Chrominance-to-Luminance Delay	C30	Steps 6 and 7 are interactive. Repeat them until the best possible results are obtained.
7	SC/H Phase	C30	

Adjustment Procedures

This section contains the adjustment procedures outlined in the previous section. Figure 5–1 shows the setup used to adjust the oscillator frequency.

AA501 DISTORTION ANALYZER

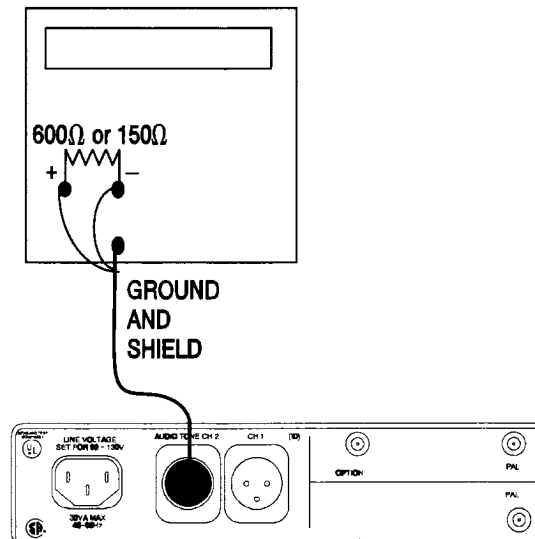

Figure 5–2: Audio amplitude calibration setup

Audio Output Amplitude

1. Connect the equipment as shown in Figure 5–2 with the following AA501 (Distortion Analyzer) settings:

Table 5–1: Setup for AA501 Distortion Analyzer.

Function	Setting
Input Level Range	Auto range
dBm Switch	In
Level Switch	In
All Filter Switches	Out

2. Disable the CH 1 ID click by moving jumper J12 to pins 2 and 3.
3. Adjust R123 to obtain the desired dB output for Audio 1 (factory setting is +8 dBm).
4. Return jumper J12 to the 1–2 position.
5. Move the cable at the TSG 111 from audio CH 1 to audio CH 2.
6. Adjust R122 to obtain the desired output level for audio CH 2. (Factory setting is +8 dBm).

Figure 5-3 shows the setup used to adjust the audio ID click frequency.

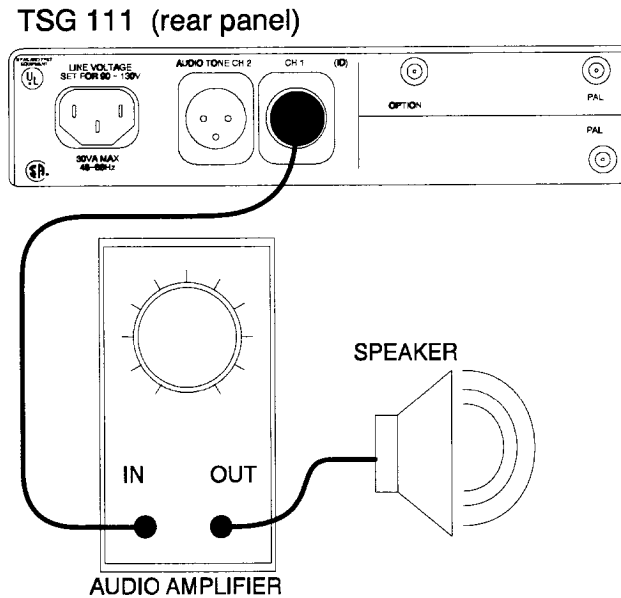

Figure 5-3: Audio ID click frequency adjustment setup

Audio ID Click Frequency

1. Connect the equipment as shown in Figure 5-3.
2. Adjust R126 for the desired interval between ID clicks. The range of adjustment is about 0.2– 4 seconds.

Connect the equipment as shown in Figure 5-4 for all remaining adjustment procedures.

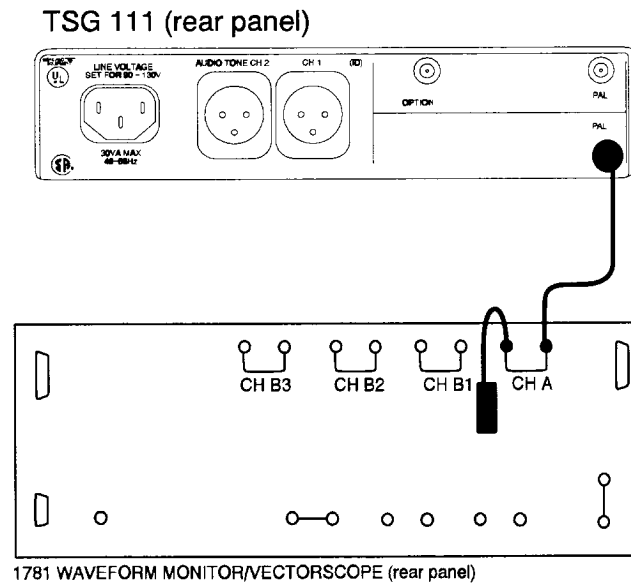

Figure 5–4: Basic setup for adjustment procedures

Table 5–2 shows the suggested Tektronix 1781 setup for the following procedures.

Table 5–2: Initial 1781 setup.

Configure	Front Panel
Coupling	DC
Left Display	VECT
Vector Grat	INT
Right Display	WFM
WFM Grat	INT
REF	EXT
ABS Units	IRE
Filter	FLAT
Vector Readout	ON
WFM Horizontal	ONE/LINE
WFM Readout	ON
Waveform Gain	X5

Gain and DC Level

1. Begin with the 1781 reference setup (Figure 5–4) and select CH A as the input.
2. Select the 5-Step signal from the TSG 111.
3. Set the 1781R to GND coupling and center the trace on a reference graticule.
4. Switch to DC coupling and adjust R20 for a DC Level of 0V by setting the blanking level to the reference graticule.
5. Select WFM + CAL at the right display section of the 1781R, set CAL for 700 mV.
6. Adjust R23 to match the top of the lower waveform with the blanking level of the upper.
7. Repeat these steps as necessary for best results.

PAL (Sin(x))/x Compensation

1. Begin with the reference setup (Figure 5–4) of the measurement set and select CH A as the input.
2. Select the Sweep signal from the TSG 111.
3. Choose WFM + CAL at the 1781 and match the top of the lower sweep with the bottom of the upper; use the dual trace to aid adjustment.
4. Adjust C21 for as flat a frequency response as possible (within 2% to 5 MHz).

NOTE. *The following two procedures are interactive. Repeat them in sequence until the best possible results are obtained.*

Chrominance-to-Luminance Delay

1. Begin with the reference setup (Figure 5–4) and select CH A as the input.
2. Select the CCIR 17 signal from the TSG 111.
3. Display the bottom of the modulated pulse using horizontal magnification to view the sine wave distortion.
4. Use the 1781's C-Y measurement feature to measure the chrominance-to-luminance delay. If necessary, adjust C30 for a delay of <5 ns.

SC/H Phase

- 1.** Begin with the reference setup (Figure 5-4) and select CH A as the input.
- 2.** Change the 1781 REF setting to INT, and the LEFT DISPLAY to SC/H.
- 3.** If necessary, adjust C30 for an SC/H Phase difference of $<5^\circ$.



Maintenance

Maintenance

This section describes selecting the power supply mains voltage and removing and replacing the Audio board.

Selecting Power Supply Mains Voltage

This section describes configuring the power supply for 110 VAC operation.



WARNING. *Dangerous voltages are present in the power supply. To ensure safety, only qualified service personnel may perform the following procedure.*

The TSG 111 is shipped from the factory configured for 220 VAC operation. To configure the TSG 111 for 110 VAC operation, follow this procedure.

1. Remove the TSG 111 power cord from the electrical mains supply.



WARNING. *Dangerous voltages are present in the power supply. Remove the power cord from the electrical mains supply before attempting this procedure. Failure to remove the power cord can result in life-threatening electrical shock.*

2. Remove the instrument access cover.
3. Locate J122 near the AC line filter and power receptacle at the right rear of the main board.
4. For 110 VAC operation, J122 should be in the 1–2–3–4 position.
5. For 220 VAC operation (the factory setting), J122 should be in the 2–3–4–5 position.
6. Reinstall the instrument access cover.
7. CHECK – that the fuse is the proper value. For 220 VAC operation, fuse F1 should be 0.2 Amp Med blow. For 110 VAC operation the fuse should be 0.4 Amp Med blow.

Removing and Replacing the Audio Board

Removing the Audio Board

Make sure that all connections, especially that of the power supply, are removed from the instrument.

1. Remove the top cover (8 Pozidriv screws fasten the top cover to the instrument).
2. Using Figure 6-1 as a guide, remove one screw from the Audio board and four screws from the rear panel (AUDIO TONE) connectors.
3. Pull the two audio connectors straight out from the rear panel.
4. Gently slide the Audio board toward the front of the instrument until the audio connectors clear the rear panel holes.
5. Lift the board and turn it over to reveal the component side.

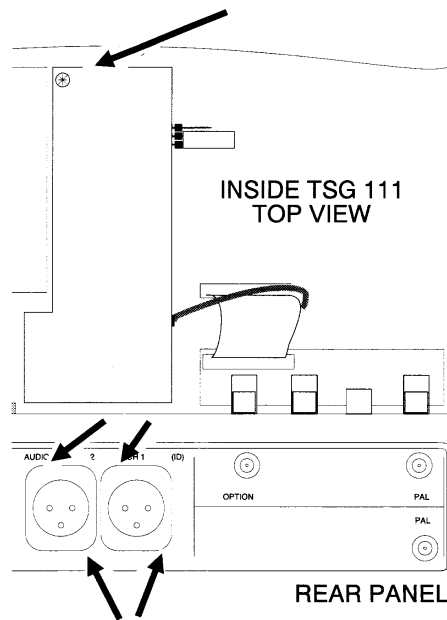

Figure 6-1: Remove these 5 Pozidriv screws to remove the Audio board from the instrument

Replacing the Audio Board

Follow these instructions to replace the audio board.

1. Turn the audio board back over to face the component side down.
2. Slide the audio connectors on the rear of the board through the rear panel holes.
3. Slide the external audio connectors through the rear-panel holes (the text on the audio connectors should be *upside down*).
4. Replace the screw on the board.
5. Replace the four audio connector screws.
6. Replace the top cover.



Replaceable Electrical Parts

Replaceable Electrical Parts

This section contains a list of the components that are replaceable for the TSG 111. Use this list to identify and order replacement parts. There is a separate Replaceable Electrical Parts list for each instrument.

Parts Ordering Information

Replacement parts are available from or through your local Tektronix, Inc., Field Office or representative.

Changes to Tektronix instruments are sometimes made to accommodate improved components as they become available and to give you the benefit of the latest circuit improvements. Therefore, when ordering parts, it is important to include the following information in your order.

- Part number
- Instrument type or model number
- Instrument serial number
- Instrument modification number, if applicable

If a part you have ordered has been replaced with a new or improved part, your local Tektronix, Inc., Field Office or representative will contact you concerning any change in part number.

Change information, if any, is located at the rear of this manual.

Using the Replaceable Electrical Parts List

The tabular information in the Replaceable Electrical Parts list is arranged for quick retrieval. Understanding the structure and features of the list will help you find all of the information you need for ordering replaceable parts.

Cross Index–Mfr. Code Number to Manufacturer

The Mfg. Code Number to Manufacturer Cross Index for the electrical parts list is located immediately after this page. The cross index provides codes, names, and addresses of manufacturers of components listed in the electrical parts list.

Abbreviations

Abbreviations conform to American National Standards Institute (ANSI) standard Y1.1.

List of Assemblies

A list of assemblies can be found at the beginning of the electrical parts list. The assemblies are listed in numerical order. When the complete component number of a part is known, this list will identify the assembly in which the part is located.

Column Descriptions

Component No. (Column 1) The component circuit number appears on the diagrams and circuit board illustrations, located in the diagrams section. Assembly numbers are also marked on each diagram and circuit board illustration, in the Diagram section and on the mechanical exploded views, in the mechanical parts list. The component number is obtained by adding the assembly number prefix to the circuit number.

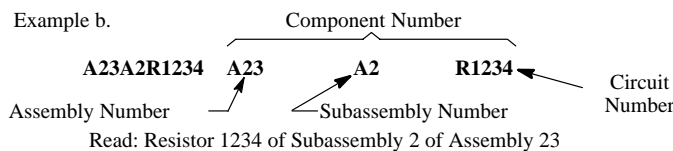
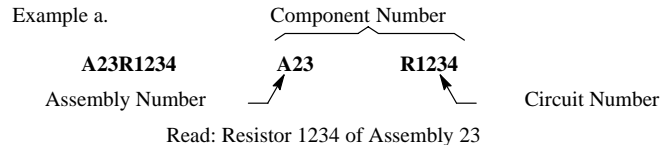

The electrical parts list is arranged by assemblies in numerical sequence (A1, with its subassemblies and parts, precedes A2, with its subassemblies and parts).

Mechanical subparts to the circuit boards are listed in the electrical parts list. These mechanical subparts are listed with their associated electrical part (for example, fuse holder follows fuse).

Chassis-mounted parts and cable assemblies have no assembly number prefix and are located at the end of the electrical parts list.

Tektronix Part No. (Column 2) Indicates part number to be used when ordering replacement part from Tektronix.

Serial/Assembly No. (Column 3 and 4) Column three (3) indicates the serial or assembly number at which the part was first used. Column four (4) indicates the serial or assembly number at which the part was removed. No serial or assembly number entered indicates part is good for all serial numbers.

Name and Description (Column 5) An item name is separated from the description by a colon (:). Because of space limitations, an item name may sometimes appear as incomplete. Use the U.S. Federal Catalog handbook H6-1 for further item name identification.

The mechanical subparts are shown as *ATTACHED PARTS* / *END ATTACHED PARTS* or *MOUNTING PARTS* / *END MOUNTING PARTS* in column five (5).

Mfr. Code (Column 6) Indicates the code number of the actual manufacturer of the part. (Code to name and address cross reference can be found immediately after this page.)

Mfr. Part No. (Column 7) Indicates actual manufacturer's part number.

Cross Index – Mfr. Code Number To Manufacturer

Mfr. code.	Manufacturer	Address	City, state, zip code
TK0435	LEWIS SCREW CO	4300 S RACINE AVE	CHICAGO IL 60609-3320
TK0891	MICONICS	1 FAIRCHILD AVE	PLAINVIEW NY 11803
TK1547	MOORE ELECTRONICS INC (DIST)	19500 SW 90TH COURT PO BOX 1030	TUALATIN OR 97062
TK1727	PHILIPS NEDERLAND BV AFD ELONCO	POSTBUS 90050	5600 PB EINDHOVEN THE NETHERLANDS
TK2058	TDK CORPORATION OF AMERICA	1600 FEEHANVILLE DRIVE	MOUNT PROSPECT, IL 60056
TK2073	TOKYO COSMOS AMERICA INC	1177 E TOWER ROAD	SCHAUMBURG, IL 60173
0FMA6	NEUTRIK USA INC	195-3 LEHIGH AVE	LAKEWOOD NJ 08701-4527
0GV52	SCHAFFNER EMC INC	9-B FADEM ROAD	SPRINGFIELD, NJ 07081
0H1N5	TOSHIBA MARCON ELECTRONICS AMERICA CORPORATION	998 FIRST EDGE DRIVE	VERNON HILLS IL 60061
0JR03	ZMAN MAGNETICS INC	7633 S 180th	KENT WA 98032
0JR05	TRIQUEST CORP	3000 LEWIS AND CLARK HWY	VANCOUVER WA 98661-2999
0KBZ5	MORELLIS Q & D PLASTICS	1812 16TH AVE	FOREST GROVE OR 97116
0LUA3	PHILIPS COMPONENTS	100 PROVIDENCE PIKE	SLATERSVILLE, RI 02876
0LXM2	LZR ELECTRONICS INC	8051 CESSNA AVENUE	GAITHERSBURG MD 20879
0MS63	QUALITY TECHNOLOGIES CORP	610 N MARY AVENUE	SUNNYVALE CA 94086
00213	MSD INC	700 ORANGE ST	DARLINGTON, SC 29532
00779	AMP INC	CUSTOMER SERVICE DEPT PO BOX 3608	HARRISBURG PA 17105-3608
01295	TEXAS INSTRUMENTS INC SEMICONDUCTOR GROUP	13500 N CENTRAL EXPY PO BOX 655303	DALLAS TX 75262-5303
04222	AVX/KYOCERA	PO BOX 867	MYRTLE BEACH SC 29577
04713	MOTOROLA INC SEMICONDUCTOR PRODUCTS SECTOR	5005 E MCDOWELL RD	PHOENIX AZ 85008-4229
07933	RAYTHEON CO	SEMICONDUCTOR DIVISION 10 GOODYEAR M/S 10A	IRVINE, CA 92718
09023	CORNELL-DUBILIER ELECTRONICS DIV FEDERAL PACIFIC ELECTRIC CO	2652 DALRYMPLE ST	SANFORD NC 27330
09922	BURNDY CORP	1 RICHARDS AVE	NORWALK CT 06856
11236	CTS CORPORATION RESISTOR NETWORKS DIVISION	406 PARR ROAD	BERNE IN 46711-9506
12954	MICROSEMI CORP - SCOTTSDALE	8700 E THOMAS RD P O BOX 1390	SCOTTSDALE AZ 85252
13409	SENSITRON SEMICONDUCTOR DIV OF RSM ELECTRON POWER INC	221 W INDUSTRY COURT	DEER PARK NY 11729-4605
13919	BURR-BROWN CORPORATION	CORP OFFICE 6730 S TUCSON BLVD PO BOX 11400	TUCSON, AZ 85706
17856	SILICONIX INC	2201 LAURELWOOD RD	SANTA CLARA CA 95054-1516
19615	ALLEN AVIONICS, INC.	224 E 2ND ST.	MINEOLA, NY 11501

Replaceable Electrical Parts

Mfr. code.	Manufacturer	Address	City, state, zip code
19701	PHILIPS COMPONENTS DISCRETE PRODUCTS DIV RESISTIVE PRODUCTS FACILITY AIRPORT ROAD	PO BOX 760	MINERAL WELLS TX 76067-0760
20932	KYOCERA AMERICA INC	8611 BALBOA AVE	SAN DIEGO, CA 92123-1580
22526	BERG ELECTRONICS INC (DUPONT)	857 OLD TRAIL RD	ETTERS PA 17319
24355	ANALOG DEVICES INC	1 TECHNOLOGY DRIVE	NORWOOD MA 02062
26364	COMPONENTS CORP	6 KINSEY PLACE	DENVILLE NJ 07834-2611
27014	NATIONAL SEMICONDUCTOR CORP	2900 SEMICONDUCTOR DR PO BOX 58090 MS 30-115	SANTA CLARA, CA 95051-0606
32997	BOURNS INC TRIMPOT DIV	1200 COLUMBIA AVE	RIVERSIDE CA 92507-2114
48726	UNITRODE INTEGRATED CIRCUITS CORP (UICC)	7 CONTINENTAL BLVD PO BOX 399	MERRIMACK NH 03054-0399
50139	ALLEN-BRADLEY COMPANY INC	ELECTRONIC COMPONENTS DIVISION 1414 ALLEN BRADLEY DRIVE	EL PASO, TX 79936
55680	NICHICON /AMERICA/ CORP	927 E STATE PKY	SCHAUMBURG IL 60195-4526
56845	DALE ELECTRONICS INC	2300 RIVERSIDE BLVD PO BOX 74	NORFOLK NE 68701-2242
57027	INTERNATIONAL RESISTIVE PRODUCTS INC	4222 S STAPLES	CORPUS CHRISTI TX 78411-2702
57668	ROHM CORPORATION	15375 BARRANCA PARKWAY SUITE B207	IRVINE CA 92718
59660	TUSONIX INC	7741 N BUSINESS PARK DR PO BOX 37144	TUCSON AZ 85740-7144
61857	SAN-0 INDUSTRIAL CORP	91-3 COLIN DRIVE	HOLBROOK NY 11741
61964	OMRON ELECTRONICS INC	1 EAST COMMERCE	SCHAUMBURG IL 60173
65786	CYPRESS SEMICONDUCTOR CORP	3901 N FIRST ST	SAN JOSE, CA 95134-1506
66182	INTERFET CORP	332 GOLD STREET	GARLAND TX 75042-6643
71400	BUSSMANN DIV OF COOPER INDUSTRIES INC	114 OLD STATE RD PO BOX 14460	ST LOUIS MO 63178
74970	JOHNSON E F CO	299 10TH AVE S W	WASECA MN 56093-2539
75498	MULTICOMP INC	3005 SW 154TH TERRACE #3	BEAVERTON OR 97006
80009	TEKTRONIX INC	14150 SW KARL BRAUN DR PO BOX 500	BEAVERTON OR 97077-0001
82567	DYNAMICS CORP OF AMERICA REEVES-HOFFMAN DIV	400 W NORTH ST	CARLISLE PA 17013-2248
91637	DALE ELECTRONIC COMPONENTS	1122 23RD ST	COLUMBUS, NE 68601

Replaceable Electrical Parts

Reference designator	Tektronix part number	Serial / Assembly number		Name & description	Mfr. code	Mfr. part number
		Effective	Discontinued			
A1	671-2289-02		030900	CIRCUIT BD ASSY:FRONT PANEL	80009	671228902
A1	671-2289-03	B030901		CIRCUIT BD ASSY:FRONT PANEL	80009	671228903
A2	671-2855-00			CIRCUIT BD ASSY:MAIN (STANDARD ONLY)	80009	671285500
A2	671-3485-00	B020596		CIRCUIT BD ASSY:MAIN (OPTION 1 ONLY)	80009	671348500
A2	671-2856-00			CIRCUIT BD ASSY:MAIN (OPTION 10 ONLY)	80009	671285600
A2	671-3531-00	B020596		CKT BD ASSY:MAIN (OPTION 1 & 10 ONLY)	80009	671353100
A2	671-3548-00	B020610		CKT BD ASSY:MAIN (OPTION 2 ONLY)	80009	671354800
A2	671-3551-00	B020610		CKT BD ASSY:MAIN (OPTION 1, 2, & 10 ONLY)	80009	671355100
A2	671-3549-00	B020610		CKT BD ASSY:MAIN (OPTION 1 & 2 ONLY)	80009	671354900
A2	671-3550-00	B020610		CKT BD ASSY:MAIN (OPTION 2, & 10 ONLY)	80009	671355000
A3	671-2290-01			CIRCUIT BD ASSY:TOP BNC	80009	671229001
A4	671-2291-01			CIRCUIT BD ASSY:BOTTOM BNC	80009	671229101
A5	671-2976-00		B029999	CIRCUIT BD ASSY:AUDIO	80009	671297600
A5	671-2976-01	B030000		CIRCUIT BD ASSY:AUDIO	80009	671297601
A1	671-2289-02		B030900	CIRCUIT BD ASSY:FRONT PANEL	80009	671228902
A1	671-2289-03	B030901		CIRCUIT BD ASSY:FRONT PANEL	80009	671228903
A1C201	281-0775-01			CAP,FXD,CERAMIC:MCL:0.1UF,20%,50V,Z5U,0.170	04222	SA105E104MAA
A1C202	281-0775-01			CAP,FXD,CERAMIC:MCL:0.1UF,20%,50V,Z5U,0.170	04222	SA105E104MAA
A1C250	281-0775-01			CAP,FXD,CERAMIC:MCL:0.1UF,20%,50V,Z5U,0.170	04222	SA105E104MAA
A1C251	281-0775-01			CAP,FXD,CERAMIC:MCL:0.1UF,20%,50V,Z5U,0.170	04222	SA105E104MAA
A1C252	281-0775-01			CAP,FXD,CERAMIC:MCL:0.1UF,20%,50V,Z5U,0.170	04222	SA105E104MAA
A1C253	281-0775-01			CAP,FXD,CERAMIC:MCL:0.1UF,20%,50V,Z5U,0.170	04222	SA105E104MAA
A1J201	131-0608-00			CONN,TERMINAL:PRESSFIT/PCB:MALE,STR,0.025SQ,0.248 MLG X 0.137 TAIL,50 GOLD,PHZ BRZ,W/FERRULE (QUANTITY 16)	22526	48283-018
A1R201	322-3143-00		671-2289-02	RES,FXD,FILM:301 OHM,1%,0.2W,TC=TOMI,SMALL BODY	91637	CCF501G301ROF
A1R201	322-3114-00	671-2289-03		RES,FXD,FILM:150 OHM,1%,0.2W,TC=TOMI,SMALL BODY	91637	CRB20-FX-150E
A1R207	322-3143-00			RES,FXD,FILM:301 OHM,1%,0.2W,TC=TOMI,SMALL BODY	91637	CCF501G301ROF
A1S202	260-2402-00			SWITCH,PUSH:SPST;MOM,NO,150 GRM FRC,SEALED,50MA,24VDC,100M OHM,W/GRN LED 20 MA MAX	61964	B3E-1300
A1S202	260-2675-00			SWITCH,PUSH,GR LED	0573	TL1240G
	366-0682-00			*ATTACHED PARTS* PUSH BUTTON:LIGHTED CAP,INSERT ASSY *END ATTACHED PARTS*	0JR05	366-0682-00

Replaceable Electrical Parts

Reference designator	Tektronix part number	Serial / Assembly number		Name & description	Mfr. code	Mfr. part number
		Effective	Discontinued			
A1S203	260-2402-00			SWITCH,PUSH:SPST;MOM,NO,150 GRM FRC,SEALED, 50MA,24VDC,100M OHM,W/GRN LED 20 MA MAX	61964	B3E-1300
A1S203	260-2675-00			SWITCH,PUSH,GR LED	0573	TL1240G
	366-0682-00			*ATTACHED PARTS*		
				PUSH BUTTON:LIGHTED CAP,INSERT ASSY	0JR05	366-0682-00
				END ATTACHED PARTS		
A1S204	260-2402-00			SWITCH,PUSH:SPST;MOM,NO,150 GRM FRC,SEALED, 50MA,24VDC,100M OHM,W/GRN LED 20 MA MAX	61964	B3E-1300
A1S204	260-2675-00			SWITCH,PUSH,GR LED	0573	TL1240G
	366-0682-00			*ATTACHED PARTS*		
				PUSH BUTTON:LIGHTED CAP,INSERT ASSY	0JR05	366-0682-00
				END ATTACHED PARTS		
A1S205	260-2402-00		671-2289-02	SWITCH,PUSH:SPST;MOM,NO,150 GRM FRC,SEALED, 50MA,24VDC,100M OHM,W/GRN LED 20 MA MAX	61964	B3E-1300
A1S205	260-2675-00	671-2289-03		SWITCH,PUSH,GR LED	0573	TL1240G
	366-0682-00			*ATTACHED PARTS*		
				PUSH BUTTON:LIGHTED CAP,INSERT ASSY	0JR05	366-0682-00
				END ATTACHED PARTS		
A1S206	260-2402-00		671-2289-02	SWITCH,PUSH:SPST;MOM,NO,150 GRM FRC,SEALED, 50MA,24VDC,100M OHM,W/GRN LED 20 MA MAX	61964	B3E-1300
A1S206	260-2675-00	671-2289-03		SWITCH,PUSH,GR LED	0573	TL1240G
	366-0682-00			*ATTACHED PARTS*		
				PUSH BUTTON:LIGHTED CAP,INSERT ASSY	0JR05	366-0682-00
				END ATTACHED PARTS		
A1S207	260-2402-00		671-2289-02	SWITCH,PUSH:SPST;MOM,NO,150 GRM FRC,SEALED, 50MA,24VDC,100M OHM,W/GRN LED 20 MA MAX	61964	B3E-1300
A1S207	260-2675-00	671-2289-03		SWITCH,PUSH,GR LED	0573	TL1240G
	366-0682-00			*ATTACHED PARTS*		
				PUSH BUTTON:LIGHTED CAP,INSERT ASSY	0JR05	366-0682-00
				END ATTACHED PARTS		
A1S208	260-2402-00		671-2289-02	SWITCH,PUSH:SPST;MOM,NO,150 GRM FRC,SEALED, 50MA,24VDC,100M OHM,W/GRN LED 20 MA MAX	61964	B3E-1300
A1S208	260-2675-00	671-2289-03		SWITCH,PUSH,GR LED	0573	TL1240G
	366-0682-00			*ATTACHED PARTS*		
				PUSH BUTTON:LIGHTED CAP,INSERT ASSY	0JR05	366-0682-00
				END ATTACHED PARTS		
A1S209	260-2402-00		671-2289-02	SWITCH,PUSH:SPST;MOM,NO,150 GRM FRC,SEALED, 50MA,24VDC,100M OHM,W/GRN LED 20 MA MAX	61964	B3E-1300
A1S209	260-2675-00	671-2289-03		SWITCH,PUSH,GR LED	0573	TL1240G
	366-0682-00			*ATTACHED PARTS*		
				PUSH BUTTON:LIGHTED CAP,INSERT ASSY	0JR05	366-0682-00
				END ATTACHED PARTS		
A1U204	156-1215-01			IC,DIGITAL:CMOS,MUX/ENCODER	27014	MM74C923N
A1U207	160-5898-02			IC,DIGITAL:NMOS,PROM;4096 X 7	80009	160589802
	136-0925-00			*MOUNTING PARTS*		
				SOCKET,DIP:PCB;24 POS,2 X 12,0.1 X 0.3 CTR,0.196 H X 0.130 TAIL,BECU,TIN,ACCOM 0.008-0.015THRU 0.014 X 0.022 LEADS	00779	2-641932-3
				END MOUNTING PARTS		
A1U209	160-6969-00			IC,DIGITAL:CMOS,PLD;EEPLD,16V8,25NS,90MA,PRGM	80009	160696900
	136-0752-00			*MOUNTING PARTS*		
				SKT,PL-IN ELEK:MICROCIRCUIT,20 DIP	09922	DILB20P-108
				END MOUNTING PARTS		
A1U210	160-7665-00			IC,DIGITAL:CMOS,PLD;OTP,EP610,35NS,37MHZ,PRGM	80009	160766500

Reference designator	Tektronix part number	Serial / Assembly number	Effective	Discontinued	Name & description	Mfr. code	Mfr. part number
	136-0925-00				*MOUNTING PARTS* SOCKET,DIP:PCB:24 POS,2 X 12,0.1 X 0.3 CTR,0.196 H X 0.130 TAIL,BECU,TIN,ACCOM 0.008-0.015THRU 0.014 X 0.022 LEADS	00779	2-641932-3
A1W201	174-2965-00				*END MOUNTING PARTS* CA ASSY,SP,ELEC:RIBBON:IDC,16,28 AWG,3.0 L,2X8,0.1 CTR,RECPT BOTH ENDS	TK1547	174-2965-00
A1DS220	150-1029-00				LT EMITTING DIO:GREEN,565NM,35MA	OMS63	MV5474CQ6480
	352-1012-00				*MOUNTING PARTS* HOLDER,LED:BLACK,ABS	OKBZ5	352-1012-00
A1DS221	150-1029-00				*END MOUNTING PARTS* LT EMITTING DIO:GREEN,565NM,35MA	OMS63	MV5474CQ6480
	352-1012-00				*MOUNTING PARTS* HOLDER,LED:BLACK,ABS	OKBZ5	352-1012-00
					END MOUNTING PARTS		
A2	671-2855-00				CIRCUIT BD ASSY:MAIN (STANDARD ONLY)	80009	671285500
A2	671-3485-00	B020596			CIRCUIT BD ASSY:MAIN (OPTION 1 ONLY)	80009	671348500
A2	671-2856-00				CIRCUIT BD ASSY:MAIN (OPTION 10 ONLY)	80009	671285600
A2	671-3531-00	B020596			CKT BD ASSY:MAIN (OPTION 1 & 10 ONLY)	80009	671353100
A2	671-3548-00				CKT BD ASSY:MAIN (OPTION 2 ONLY)	80009	671354800
A2	671-3551-00				CKT BD ASSY:MAIN (OPTION 1, 2, & 10 ONLY)	80009	671355100
A2	671-3549-00				CKT BD ASSY:MAIN (OPTION 1 & 2 ONLY)	80009	671354900
A2	671-3550-00				CKT BD ASSY:MAIN (OPTION 2, & 10 ONLY)	80009	671355000
A2C1	281-0775-01				CAP,FXD,CERAMIC:MCL:0.1UF,20%,50V,Z5U,0.170	04222	SA105E104MAA
A2C2	281-0775-01				CAP,FXD,CERAMIC:MCL:0.1UF,20%,50V,Z5U,0.170	04222	SA105E104MAA
A2C3	281-0775-01				CAP,FXD,CERAMIC:MCL:0.1UF,20%,50V,Z5U,0.170	04222	SA105E104MAA
A2C5	281-0775-01				CAP,FXD,CERAMIC:MCL:0.1UF,20%,50V,Z5U,0.170	04222	SA105E104MAA
A2C6	281-0775-01				CAP,FXD,CERAMIC:MCL:0.1UF,20%,50V,Z5U,0.170	04222	SA105E104MAA
A2C7	281-0775-01				CAP,FXD,CERAMIC:MCL:0.1UF,20%,50V,Z5U,0.170	04222	SA105E104MAA
A2C8	281-0775-01				CAP,FXD,CERAMIC:MCL:0.1UF,20%,50V,Z5U,0.170	04222	SA105E104MAA
A2C9	290-0973-00				CAP,FXD,ELCTLT:100UF,20%,25VDC	0H1N5	CEUSM1E101
A2C10	290-0973-00				CAP,FXD,ELCTLT:100UF,20%,25VDC	0H1N5	CEUSM1E101
A2C13	283-0177-00				CAP,FXD,CER DI:1UF,+80-20%,25V	04222	SR303E105ZAA
A2C15	283-0177-00				CAP,FXD,CER DI:1UF,+80-20%,25V	04222	SR303E105ZAA
A2C20	281-0810-00				CAP,FXD,CERAMIC:MLC:5.6PF,+/-0.5PF,100V,0.100 X 0.170	04222	SA102A5R6DAA
A2C21	281-0153-00				CAP,VAR,AIR DI:1.7-10PF,150V	74970	187-0106-055
A2C30	281-0123-00				CAP,VAR,CER DI:5-25PF,100V	59660	518-000A5-25
A2C37	281-0775-01				CAP,FXD,CERAMIC:MCL:0.1UF,20%,50V,Z5U,0.170	04222	SA105E104MAA
A2C38	281-0775-01				CAP,FXD,CERAMIC:MCL:0.1UF,20%,50V,Z5U,0.170	04222	SA105E104MAA
A2C39	283-0220-02				CAP,FXD,CER DI:0.01UF,20%,50V	04222	SR075C103MAAAP1
A2C40	281-0775-01				CAP,FXD,CERAMIC:MCL:0.1UF,20%,50V,Z5U,0.170	04222	SA105E104MAA
A2C41	281-0775-01				CAP,FXD,CERAMIC:MCL:0.1UF,20%,50V,Z5U,0.170	04222	SA105E104MAA
A2C42	283-0177-00				CAP,FXD,CER DI:1UF,+80-20%,25V	04222	SR303E105ZAA
A2C43	283-0220-02				CAP,FXD,CER DI:0.01UF,20%,50V	04222	SR075C103MAAAP1

Replaceable Electrical Parts

Reference designator	Tektronix part number	Serial / Assembly number		Name & description	Mfr. code	Mfr. part number
		Effective	Discontinued			
A2C183	290-1290-00			CAP,FXD,ALUM::2200UF,20%,25V,ESR=0.053 OHM (100KHZ,20C),16MM X 31.5MM,LOW IMP,105C	0H1N5	CEAFM1E222M-E
A2C186	281-0775-01			CAP,FXD,CERAMIC:MCL:0.1UF,20%,50V,Z5U,0.170	04222	SA105E104MAA
A2C188	290-0943-00			CAP,FXD,ALUM::47UF,+50-20%,25V,6 X 11MM	0H1N5	CEUSM1E470-Q
A2C190	283-0177-00			CAP,FXD,CER DI:1UF,+80-20%,25V	04222	SR303E105ZAA
A2C191	281-0775-01			CAP,FXD,CERAMIC:MCL:0.1UF,20%,50V,Z5U,0.170	04222	SA105E104MAA
A2C192	281-0775-01			CAP,FXD,CERAMIC:MCL:0.1UF,20%,50V,Z5U,0.170	04222	SA105E104MAA
A2C197	281-0775-01			CAP,FXD,CERAMIC:MCL:0.1UF,20%,50V,Z5U,0.170	04222	SA105E104MAA
A2C198	281-0775-01			CAP,FXD,CERAMIC:MCL:0.1UF,20%,50V,Z5U,0.170	04222	SA105E104MAA
A2C254	281-0775-01			CAP,FXD,CERAMIC:MCL:0.1UF,20%,50V,Z5U,0.170	04222	SA105E104MAA
A2C255	281-0775-01			CAP,FXD,CERAMIC:MCL:0.1UF,20%,50V,Z5U,0.170	04222	SA105E104MAA
A2C257	281-0775-01			CAP,FXD,CERAMIC:MCL:0.1UF,20%,50V,Z5U,0.170	04222	SA105E104MAA
A2C263	283-0637-00			CAP,FXD,MICA DI:20PF,2.5%,500V	TK0891	RDM15ED200D03
A2C268	281-0775-01			CAP,FXD,CERAMIC:MCL:0.1UF,20%,50V,Z5U,0.170	04222	SA105E104MAA
A2C269	281-0775-01			CAP,FXD,CERAMIC:MCL:0.1UF,20%,50V,Z5U,0.170	04222	SA105E104MAA
A2C270	281-0775-01			CAP,FXD,CERAMIC:MCL:0.1UF,20%,50V,Z5U,0.170	04222	SA105E104MAA
A2C271	281-0775-01			CAP,FXD,CERAMIC:MCL:0.1UF,20%,50V,Z5U,0.170	04222	SA105E104MAA
A2C272	281-0775-01			CAP,FXD,CERAMIC:MCL:0.1UF,20%,50V,Z5U,0.170	04222	SA105E104MAA
A2C273	281-0775-01			CAP,FXD,CERAMIC:MCL:0.1UF,20%,50V,Z5U,0.170	04222	SA105E104MAA
A2C274	281-0775-01			CAP,FXD,CERAMIC:MCL:0.1UF,20%,50V,Z5U,0.170	04222	SA105E104MAA
A2C275	281-0775-01			CAP,FXD,CERAMIC:MCL:0.1UF,20%,50V,Z5U,0.170	04222	SA105E104MAA
A2C276	281-0775-01			CAP,FXD,CERAMIC:MCL:0.1UF,20%,50V,Z5U,0.170	04222	SA105E104MAA
A2C277	281-0775-01			CAP,FXD,CERAMIC:MCL:0.1UF,20%,50V,Z5U,0.170	04222	SA105E104MAA
A2C278	281-0775-01			CAP,FXD,CERAMIC:MCL:0.1UF,20%,50V,Z5U,0.170	04222	SA105E104MAA
A2C281	281-0775-01			CAP,FXD,CERAMIC:MCL:0.1UF,20%,50V,Z5U,0.170	04222	SA105E104MAA
A2C282	281-0775-01			CAP,FXD,CERAMIC:MCL:0.1UF,20%,50V,Z5U,0.170	04222	SA105E104MAA
A2C283	281-0775-01			CAP,FXD,CERAMIC:MCL:0.1UF,20%,50V,Z5U,0.170	04222	SA105E104MAA
A2C284	281-0775-01			CAP,FXD,CERAMIC:MCL:0.1UF,20%,50V,Z5U,0.170	04222	SA105E104MAA
A2C290	283-0203-00			CAP,FXD,CER DI:0.47UF,20%,50V	04222	SR305C474MAA
A2C291	290-0845-00			CAP,FXD,ELCTL:330UF,+50-10%,25V	55680	UVX1H331MPA
A2C292	283-0203-00			CAP,FXD,CER DI:0.47UF,20%,50V	04222	SR305C474MAA
A2C293	283-0203-00			CAP,FXD,CER DI:0.47UF,20%,50V	04222	SR305C474MAA
A2C294	290-0845-00			CAP,FXD,ELCTL:330UF,+50-10%,25V	55680	UVX1H331MPA
A2C295	290-0845-00			CAP,FXD,ELCTL:330UF,+50-10%,25V	55680	UVX1H331MPA
A2C296	290-0845-00			CAP,FXD,ELCTL:330UF,+50-10%,25V	55680	UVX1H331MPA
A2C297	290-1301-00			CAP,FXD,ALUM::2700UF,20%,10V,12.5 X 30MM (0.492 X 1.180)	0H1N5	CEEFM1A272M7
A2C298	283-0203-00			CAP,FXD,CER DI:0.47UF,20%,50V	04222	SR305C474MAA
A2C299	283-0203-00			CAP,FXD,CER DI:0.47UF,20%,50V	04222	SR305C474MAA
A2C300	290-0973-01			CAP,FXD,ALUM::100UF,20%,25VDC	55680	UVX1E101MEA1TA
A2C301	290-0973-01			CAP,FXD,ALUM::100UF,20%,25VDC	55680	UVX1E101MEA1TA
A2C302	283-0398-00			CAP,FXD,CER DI:680PF,2%,100V	04222	SR201A681GAA
A2C303	283-0398-00			CAP,FXD,CER DI:680PF,2%,100V	04222	SR201A681GAA
A2C304	283-0220-02			CAP,FXD,CER DI:0.01UF,20%,50V	04222	SR075C103MAAAP1
A2C305	281-0775-01			CAP,FXD,CERAMIC:MCL:0.1UF,20%,50V,Z5U,0.170	04222	SA105E104MAA
A2C306	283-0203-00			CAP,FXD,CER DI:0.47UF,20%,50V	04222	SR305C474MAA
A2C307	283-0005-00			CAP,FXD,CER DI:0.01UF,+100-0%,250V	04222	SR30VE103ZAA
A2C308	283-0032-00			CAP,FXD,CER DI:470PF,5%,500V	59660	831 621 Z5E0 47
A2C314	281-0775-01			CAP,FXD,CERAMIC:MCL:0.1UF,20%,50V,Z5U,0.170	04222	SA105E104MAA
A2C321	281-0775-01	B020610		CAP,FXD,CERAMIC:MCL:0.1UF,20%,50V,Z5U,0.170 X 0.100,AXIAL	04222	SA105E104MAA
A2C322	283-0204-00	B020610		CAP,FXD,CER DI:0.01UF,20%,50V SQUARE	04222	SR155E103MAA
A2C323	281-0775-01	B020610		CAP,FXD,CERAMIC:MCL:0.1UF,20%,50V,AXIAL	04222	SA105E104MAA
A2C324	283-0204-00	B020610		CAP,FXD,CER DI:0.01UF,20%,50V SQUARE	04222	SR155E103MAA

Reference designator	Tektronix part number	Serial / Assembly number		Name & description	Mfr. code	Mfr. part number
		Effective	Discontinued			
A2C325	281-0775-01	B020610		CAP,FXD,CERAMIC:MCL,0.1UF,20%,50V,AXIAL	04222	SA105E104MAA
A2C326	281-0775-01	B020610		CAP,FXD,CERAMIC:MCL,0.1UF,20%,50V,AXIAL	04222	SA105E104MAA
A2C327	281-0775-01	B020610		CAP,FXD,CERAMIC:MCL,0.1UF,20%,50V,AXIAL	04222	SA105E104MAA
A2C328	281-0810-00	B020610		CAP,FXD,CERAMIC:MLC,5.6PF,+/-0.5PF,100V,,AXIAL,MI	04222	SA102A5R6DAA
A2C329	281-0153-00	B020610		CAP,VAR,AIR DI:1.7-10PF,150V TOP ADJ		187-0106-055
A2C330	283-0177-05	B020610		CAP,FXD,CER DI:1UF,+80-20%,25V SQUARE,MI	20932	5030ES25RD105Z
A2C336	281-0775-01	B020610		CAP,FXD,CERAMIC:MCL,0.1UF,20%,50V,AXIAL	04222	SA105E104MAA
A2C351	281-0775-01			CAP,FXD,CERAMIC:MCL:0.1UF,20%,50V,Z5U,0.170	04222	SA105E104MAA
A2C352	281-0775-01			CAP,FXD,CERAMIC:MCL:0.1UF,20%,50V,Z5U,0.170	04222	SA105E104MAA
A2C353	281-0775-01			CAP,FXD,CERAMIC:MCL:0.1UF,20%,50V,Z5U,0.170	04222	SA105E104MAA
A2C356	283-0796-01			CAP,FXD,MICA DI:100PF,5%,500V,TAPE & AMMO	09023	CDA10FD101J03
A2F1	159-0044-00			FUSE,CARTRIDGE:3AG,0.2A,250V,20SEC, *MOUNTING PARTS*	71400	MDL 2/10
	344-0329-00			CLIP,ELECTRICAL:PCB:FEMALE,STR,ACCOM 5 X 20MM FUSE,5.9MM H X 3.2MM TAIL,5MM PTH SP,1.3MM DIA PTH,BRONZE TIN PLATED (QUANTITY 2) *END MOUNTING PARTS*	61857	H-0011-2
A2F2	159-0021-00			FUSE,CARTRIDGE:3AG,2A,250V,FAST BLOW, *MOUNTING PARTS*	71400	AGC-2
	344-0329-00			CLIP,ELECTRICAL:PCB:FEMALE,STR,ACCOM 5 X 20MM FUSE,5.9MM H X 3.2MM TAIL,5MM PTH SP,1.3MM DIA PTH,BRONZE TIN PLATED (QUANTITY 2)	61857	H-0011-2
A2FL4	119-4316-00	B020610		FILTER,LOWPASS:PCB,SIP,DELAY EQUALIZED,6MHZ CUTOFF, *END MOUNTING PARTS*	19615	F4105
A2J4	131-0608-00			CONN,TERMINAL:PRESSFIT/ PCB:MALE,STR,0.025SQ,0.248 MLG X 0.137 TAIL,50 GOLD,PHZ BRZ,W/FERRULE (QUANTITY 10)	22526	48283-018
A2J6	131-0608-00			CONN,TERMINAL:PRESSFIT/ PCB:MALE,STR,0.025SQ,0.248 MLG X 0.137 TAIL,50 GOLD,PHZ BRZ,W/FERRULE (QUANTITY 3)	22526	48283-018
A2J130	131-0608-00	B020610		CONN,TERMINAL:PRESSFIT/PCB,MALE,STR,0.025 SQ,0.248 MLG X 0.137 TAIL,50 GOLD,PHZ BRZ,W/FERRULE	22526	48283-018
A2J145	131-0608-00	B020610		CONN,TERMINAL:PRESSFIT/PCB,MALE,STR,0.025 SQ,0.248 MLG X 0.137 TAIL,50 GOLD,PHZ BRZ,W/FERRULE	22526	48283-018
A2J40	131-0608-00			CONN,TERMINAL:PRESSFIT/ PCB:MALE,STR,0.025SQ,0.248 MLG X 0.137 TAIL,50 GOLD,PHZ BRZ,W/FERRULE (QUANTITY 2)	22526	48283-018
A2J50	131-0608-00			CONN,TERMINAL:PRESSFIT/ PCB:MALE,STR,0.025SQ,0.248 MLG X 0.137 TAIL,50 GOLD,PHZ BRZ,W/FERRULE (QUANTITY 2)	22526	48283-018
A2J60	131-0608-00			CONN,TERMINAL:PRESSFIT/ PCB:MALE,STR,0.025SQ,0.248 MLG X 0.137 TAIL,50 GOLD,PHZ BRZ,W/FERRULE (QUANTITY 2)	22526	48283-018

Replaceable Electrical Parts

Reference designator	Tektronix part number	Serial / Assembly number		Name & description	Mfr. code	Mfr. part number
		Effective	Discontinued			
A2J70	131-0608-00			CONN, TERMINAL:PRESSFIT/ PCB;MALE, STR,0.025SQ,0.248 MLG X 0.137 TAIL,50 GOLD,PHZ BRZ,W/FERRULE (QUANTITY 2)	22526	48283-018
A2J106	131-0608-00			CONN, TERMINAL:PRESSFIT/ PCB;MALE, STR,0.025SQ,0.248 MLG X 0.137 TAIL,50 GOLD,PHZ BRZ,W/FERRULE (QUANTITY 16)	22526	48283-018
A2J107	131-0608-00			CONN, TERMINAL:PRESSFIT/ PCB;MALE, STR,0.025SQ,0.248 MLG X 0.137 TAIL,50 GOLD,PHZ BRZ,W/FERRULE (QUANTITY 16)	22526	48283-018
A2J110	131-0608-00			CONN, TERMINAL:PRESSFIT/ PCB;MALE, STR,0.025SQ,0.248 MLG X 0.137 TAIL,50 GOLD,PHZ BRZ,W/FERRULE (QUANTITY 3)	22526	48283-018
A2J111	131-0608-00			CONN, TERMINAL:PRESSFIT/ PCB;MALE, STR,0.025SQ,0.248 MLG X 0.137 TAIL,50 GOLD,PHZ BRZ,W/FERRULE (QUANTITY 3)	22526	48283-018
A2J112	131-0608-00			CONN, TERMINAL:PRESSFIT/ PCB;MALE, STR,0.025SQ,0.248 MLG X 0.137 TAIL,50 GOLD,PHZ BRZ,W/FERRULE (QUANTITY 3)	22526	48283-018
A2J122	131-0608-00			CONN, TERMINAL:PRESSFIT/ PCB;MALE, STR,0.025SQ,0.248 MLG X 0.137 TAIL,50 GOLD,PHZ BRZ,W/FERRULE (QUANTITY 5)	22526	48283-018
A2J124	131-0608-00			CONN, TERMINAL:PRESSFIT/ PCB;MALE, STR,0.025SQ,0.248 MLG X 0.137 TAIL,50 GOLD,PHZ BRZ,W/FERRULE (QUANTITY 3)	22526	48283-018
A2J126	131-5527-00			JACK,POWER DC:PCB;MALE,RTANG,2MM PIN,11MMH (0.433) X 3.5MM(0.137) TAIL,9MM(0.354) W,TIN,W/ SWITCH, DC PWR JACK,2.0 MM	0LXM2	DJ005A
A2J128	131-0608-00			CONN, TERMINAL:PRESSFIT/ PCB;MALE, STR,0.025SQ,0.248 MLG X 0.137 TAIL,50 GOLD,PHZ BRZ,W/FERRULE (QUANTITY 10)	22526	48283-018
A2L2	108-1491-00			INDUCTOR,FXD:SIGNAL;9.9UH,5.5%,TOROID CORE	0JR03	108-1491-00
A2L4	108-0538-00			INDUCTOR,FXD:CUSTOM,POWER:2.7UH,10%,IDC<1 A,RDC<0.168 OHM,Q>34@7.9MHZ,SRF>74MHZ	0JR03	108-0538-00
A2L28	108-0245-00			INDUCTOR,FXD:CUSTOM,POWER:3.9UH,10%,IDC<800	0JR03	108-0245-00
A2L29	108-0245-00			INDUCTOR,FXD:CUSTOM,POWER:3.9UH,10%,IDC<800	0JR03	108-0245-00
A2L60	108-1263-00			INDUCTOR,FXD:POWER:10UH,10%,I<2.1A,RDC<0.043 OHM,Q>20,SRF>19MHZ,BOBBIN	TK2058	TSL0707-100K1R9
A2L70	108-1263-00			INDUCTOR,FXD:POWER:10UH,10%,I<2.1A,RDC<0.043 OHM,Q>20,SRF>19MHZ,BOBBIN	TK2058	TSL0707-100K1R9
A2L71	108-0538-00			INDUCTOR,FXD:CUSTOM,POWER:2.7UH,10%,IDC<1 A,RDC<0.168 OHM,Q>34@7.9MHZ,SRF>74MHZ	0JR03	108-0538-00
A2L75	108-1263-00			INDUCTOR,FXD:POWER:10UH,10%,I<2.1A,RDC<0.043 OHM,Q>20,SRF>19MHZ,BOBBIN	TK2058	TSL0707-100K1R9
A2L81	108-1491-00	B020610		INDUCTOR,FXD:SIGNAL;9.9UH,5.5%,TOROID CORE,	0JR03	108-1491-00
A2P6	131-0993-02			BUS,CONDUCTOR:SHUNT ASSEMBLY,RED	00779	1-850100-0
A2P40	131-0993-02			BUS,CONDUCTOR:SHUNT ASSEMBLY,RED	00779	1-850100-0
A2P50	131-0993-02			BUS,CONDUCTOR:SHUNT ASSEMBLY,RED	00779	1-850100-0

Reference designator	Tektronix part number	Serial / Assembly number		Name & description	Mfr. code	Mfr. part number
		Effective	Discontinued			
A2P60	131-0993-02			BUS,CONDUCTOR:SHUNT ASSEMBLY,RED	00779	1-850100-0
A2P70	131-0993-02			BUS,CONDUCTOR:SHUNT ASSEMBLY,RED	00779	1-850100-0
A2P110	131-0993-02			BUS,CONDUCTOR:SHUNT ASSEMBLY,RED	00779	1-850100-0
A2P111	131-0993-02			BUS,CONDUCTOR:SHUNT ASSEMBLY,RED	00779	1-850100-0
A2P112	131-0993-02			BUS,CONDUCTOR:SHUNT ASSEMBLY,RED	00779	1-850100-0
A2P122	198-5783-00			WIRE,SET ELEC:TSG111/TSG121/TSG131	TK1547	198-5783-00
A2P130	131-0993-02	B020610		CONN,BOX:SHUNT,FEMALE,STR,1 X 2,0.1 CTR,0.385 H,30 GOLD,RED,JUMPER	00779	1-850100-0
A2Q30	151-0190-00			XSTR,SIG:BIPOLAR,NPN:40V,200MA,300MHZ,AMPL	04713	2N3904
A2Q100	151-1171-00			XSTR,PWR:MOS,N-CH:50V,12A,0.12 OHM	04713	MTF15N05E
A2R14	307-0051-00			RES,FXD,CMPSN:2.7 OHM,5%,0.5W	50139	EB27G5
A2R15	307-0051-00			RES,FXD,CMPSN:2.7 OHM,5%,0.5W	50139	EB27G5
A2R20	311-0633-00			RES,VAR,NONWWW:TRMR,5K OHM,0.5W	32997	3329H-L58-502
A2R21	322-3133-00			RES,FXD,FILM:237 OHM,1%,0.2W,TC=TOMI,SMALL BODY	91637	CCF50-2F237R0F
A2R22	322-3193-00			RES,FXD:METAL FILM:1K OHM,1%,0.2W,TC=100 PPM	91637	CCF501G10000F
A2R23	311-0634-00			RES,VAR,NONWWW:TRMR,500 OHM,0.5W	32997	3329H-L58-501
A2R24	322-3299-00			RES,FXD,FILM:12.7K OHM,1%,0.2W,TC=TOMI,SMALL BODY	91637	CCF501G12701F
A2R30	322-3085-07			RES,FXD:METAL FILM:75 OHM,0.1%,0.2W,TC=25 PPM	91637	CCF502-C75ROOB T
A2R31	322-3226-00			RES,FXD:METAL FILM:2.21K OHM,1%,0.2W,TC=100	91637	CCF501G22100F
A2R42	322-3239-00			RES,FXD,FILM:3.01K OHM,1%,0.2W,TC=TOMI,SMALL BODY	91637	CCF501G30100F
A2R45	322-3056-01			RES,FXD,FILM:37.4 OHM,0.5%,0.2W,TC=T0,SMALL BODY	57668	CRB20 DXE 37E4
A2R46	322-3085-07			RES,FXD:METAL FILM:75 OHM,0.1%,0.2W,TC=25 PPM	91637	CCF502-C75ROOB T
A2R48	317-0036-00			RES,FXD,CMPSN:3.6 OHM,5%,0.125W	50139	BB36G5
A2R49	322-3193-00			RES,FXD:METAL FILM:1K OHM,1%,0.2W,TC=100 PPM	91637	CCF501G10000F
A2R50	322-3126-01			RES,FXD,FILM:200 OHM,0.5%,0.2W,TC=TOSMALL BODY	91637	CCF501G200R0D
A2R51	322-3226-00			RES,FXD:METAL FILM:2.21K OHM,1%,0.2W,TC=100	91637	CCF501G22100F
A2R52	322-3213-00			RES,FXD,FILM:1.62K OHM,1%,0.2W,TC=TOTAPED &	91637	CCF501G16200F
A2R53	322-3213-00			RES,FXD,FILM:1.62K OHM,1%,0.2W,TC=TOTAPED &	91637	CCF501G16200F
A2R54	317-0036-00			RES,FXD,CMPSN:3.6 OHM,5%,0.125W	50139	BB36G5
A2R140	315-0100-00			RES,FXD,FILM:10 OHM,5%,0.25W	TK1727	SFR25 2322-182-
A2R197	322-3085-07			RES,FXD:METAL FILM:75 OHM,0.1%,0.2W,TC=25 PPM	91637	CCF502-C75ROOB T
A2R198	307-0503-00			RES NTWK,FXD,FI:(9) 510 OHM,20%,0.125WTC=50PPM/DEG C	11236	750-101-R510 OR
A2R199	322-3239-00			RES,FXD,FILM:3.01K OHM,1%,0.2W,TC=TOMI,SMALL BODY	91637	CCF501G30100F
A2R231	322-3193-00			RES,FXD:METAL FILM:1K OHM,1%,0.2W,TC=100 PPM	91637	CCF501G10000F
A2R232	322-3243-00			RES,FXD:METAL FILM:3.32K OHM,1%,0.2W,TC=100	91637	CCF50-1-G33200F
A2R233	322-3243-00			RES,FXD:METAL FILM:3.32K OHM,1%,0.2W,TC=100	91637	CCF50-1-G33200F
A2R248	322-3243-00			RES,FXD:METAL FILM:3.32K OHM,1%,0.2W,TC=100	91637	CCF50-1-G33200F
A2R261	315-0101-00			RES,FXD,FILM:100 OHM,5%,0.25W,MI	TK1727	SFR25 2322-181-
A2R262	315-0331-00			RES,FXD,FILM:330 OHM,5%,0.25W	TK1727	SFR25 2322-181-
A2R263	322-3235-00			RES,FXD:METAL FILM:2.74K OHM,1%,0.2W,TC=100	91637	CCF501G27400F
A2R264	322-3235-00			RES,FXD:METAL FILM:2.74K OHM,1%,0.2W,TC=100	91637	CCF501G27400F
A2R265	322-3235-00			RES,FXD:METAL FILM:2.74K OHM,1%,0.2W,TC=100	91637	CCF501G27400F
A2R266	322-3414-00			RES,FXD:METAL FILM:200K OHM,1%,0.2W,TC=100PPM	91637	CCF501G20002F
A2R267	322-3258-00			RES,FXD:METAL FILM:4.75K OHM,1%,0.2W,TC=100	56845	CCF50-2-G4751FT

Replaceable Electrical Parts

Reference designator	Tektronix part number	Serial / Assembly		Name & description	Mfr. code	Mfr. part number
		Effective	Discontinued			
A2R268	322-3181-00			RES,FXD,FILM:750 OHM,1%,0.2W,TC=T0MI,SMALL BODY	91637	CCF501G750ROF
A2R269	308-0463-00			RES,FXD,WW:0.3 OHM,1%,3W	00213	1240SR3000F 0.3
A2R270	322-3222-00			RES,FXD:METAL FILM;2K OHM,1%,0.2W,TC=100 PPM	91637	CCF501G20000F
A2R271	315-0100-00			RES,FXD,FILM:10 OHM,5%,0.25W,	TK1727	SFR25 2322-182-
A2R273	322-3097-00			RES,FXD:METAL FILM;100 OHM,1%,0.2W,TC=100 PPM	91637	CCF501G100R0F
A2R274	322-3056-01			RES,FXD,FILM:37.4 OHM,0.5%,0.2W,TC=T0,SMALL BODY	57668	CRB20 DXE 37E4
A2R275	322-3056-01			RES,FXD,FILM:37.4 OHM,0.5%,0.2W,TC=T0,SMALL BODY	57668	CRB20 DXE 37E4
A2R300	322-3193-00	B020610		RES,FXD:METAL FILM,1K OHM,1%,0.2W	57668	CRB20T68EFX1001
A2R301	322-3133-00	B020610		RES,FXD,FILM:237 OHM,1%,0.2W	91637	CCF50-2370F-R36
A2R302	322-3301-00	B020610		RES,FXD,FILM:13.3K OHM,1%,0.2W	57668	CRB20 FXE 13K3
A2R303	322-3212-00	B020610		RES,FXD,FILM:1.58K OHM,1%,0.2W	57668	CRB20 FXE 1K58
A2R304	322-3056-01	B020610		RES,FXD,FILM:37.4 OHM,0.5%,0.2W	57668	CRB20 DXE 37E4
A2R305	322-3056-01	B020610		RES,FXD,FILM:37.4 OHM,0.5%,0.2W	57668	CRB20 DXE 37E4
A2R315	322-3056-01	B020610		RES,FXD,FILM:37.4 OHM,0.5%,0.2W	57668	CRB20 DXE 37E4
A2R316	317-0036-00	B020610		RES,FXD,FILM:3.6 OHM,5%,0.125W	50139	BB36G5
A2R317	317-0036-00	B020610		RES,FXD,FILM:3.6 OHM,5%,0.125W	50139	BB36G5
A2R318	322-3226-00	B020610		RES,FXD:METAL FILM,2.21K OHM,1%,0.2W	57668	CRB20T68EFX2211
A2R319	322-3226-00	B020610		RES,FXD:METAL FILM,2.21K OHM,1%,0.2W	57668	CRB20T68EFX2211
A2R320	322-3193-00	B020610		RES,FXD:METAL FILM,1K OHM,1%,0.2W	57668	CRB20T68EFX1001
A2R321	322-3213-00	B020610		RES,FXD,FILM:1.62K OHM,1%,0.2W	57668	CRB20 FXE 1K62
A2R322	322-3213-00	B020610		RES,FXD,FILM:1.62K OHM,1%,0.2W	57668	CRB20 FXE 1K62
A2R323	322-3085-07	B020610		RES,FXD:METAL FILM,75 OHM,0.1%,0.2W	91637	CCF502-C75ROOB T
A2R325	311-2234-00	B020610		RES,VAR,TRMR:CERMET,5K OHM,20%,0.5W	TK2073	GF06UT2 502 M L20
A2R327	322-3243-00	B020610		RES,FXD:METAL FILM,3.32K OHM,1%,0.2W	91637	CCF50-3321F-R36
A2R328	311-2230-00	B020610		RES,VAR,TRMR:CERMET,500 OHM,20%,0.5W	TK2073	GF06UT2 501 M L20
A2R336	322-3085-07	B020610		RES,FXD:METAL FILM,75 OHM,0.1%,0.2W	91637	CCF502-C75ROOB T
A2R341	322-3085-07			RES,FXD:METAL FILM;75 OHM,0.1%,0.2W,TC=25 PPM	91637	CCF502-C75ROOB T
A2R342	322-3085-07			RES,FXD:METAL FILM;75 OHM,0.1%,0.2W,TC=25 PPM	91637	CCF502-C75ROOB T
A2R343	322-3085-07			RES,FXD:METAL FILM;75 OHM,0.1%,0.2W,TC=25 PPM	91637	CCF502-C75ROOB T
A2R344	322-3085-07			RES,FXD:METAL FILM;75 OHM,0.1%,0.2W,TC=25 PPM	91637	CCF502-C75ROOB T
A2R345	322-3085-07			RES,FXD:METAL FILM;75 OHM,0.1%,0.2W,TC=25 PPM	91637	CCF502-C75ROOB T
A2R346	322-3085-07			RES,FXD:METAL FILM;75 OHM,0.1%,0.2W,TC=25 PPM	91637	CCF502-C75ROOB T
A2R347	322-3085-07			RES,FXD:METAL FILM;75 OHM,0.1%,0.2W,TC=25 PPM	91637	CCF502-C75ROOB T
A2R348	322-3085-07			RES,FXD:METAL FILM;75 OHM,0.1%,0.2W,TC=25 PPM	91637	CCF502-C75ROOB T
A2R349	322-3085-07			RES,FXD:METAL FILM;75 OHM,0.1%,0.2W,TC=25 PPM	91637	CCF502-C75ROOB T
A2R350	322-3085-07			RES,FXD:METAL FILM;75 OHM,0.1%,0.2W,TC=25 PPM	91637	CCF502-C75ROOB T
A2R351	322-3085-07			RES,FXD:METAL FILM;75 OHM,0.1%,0.2W,TC=25 PPM	91637	CCF502-C75ROOB T
A2R352	322-3085-07			RES,FXD:METAL FILM;75 OHM,0.1%,0.2W,TC=25 PPM	91637	CCF502-C75ROOB T

Reference designator	Tektronix part number	Serial / Assembly number	Effective	Discontinued	Name & description	Mfr. code	Mfr. part number
A2R357	322-3243-00				RES,FXD:METAL FILM;3.32K OHM,1%,0.2W,TC=100	91637	CCF50-1-G33200F
A2R358	322-3243-00				RES,FXD:METAL FILM;3.32K OHM,1%,0.2W,TC=100	91637	CCF50-1-G33200F
A2T1	120-1902-00				TRANSFORMER,PWR:DUAL PRI/SEC,PRI 115/230 VAC, 50/60HZ,SEC 2-20 VAC,1.2A,2.87 X 2.25 X 1.25 HIGH, BOARD MOUNT	80009	120190200
A2T2	120-1785-00				TRANSFORMER:FLYBACK,+/- 5V 2A, +/- 15V0.2A,	75498	128-7045-00
A2TP11	214-4085-00	B020610			TERM,TEST POINT:0.070 ID,0.220 H,0.063 DIA PCB,0.015 X 0.032 BRASS,W/ RED NYLON COLLAR	26364	TP104-01-02
A2TP14	214-4085-00	B020610			TERM,TEST POINT:0.070 ID,0.220 H,0.063 DIA PCB,0.015 X 0.032 BRASS,W/ RED NYLON COLLAR	26364	TP104-01-02
A2TP16	214-4085-00	B020610			TERM,TEST POINT:0.070 ID,0.220 H,0.063 DIA PCB,0.015 X 0.032 BRASS,W/ RED NYLON COLLAR	26364	TP104-01-02
A2U2	156-4024-00				IC,LINEAR:BIPOLAR,OP-AMP;190MHZ,CURRENT FEEDBACK,1 TO 40 GAIN RANGE	24355	AD9617JN
A2U22	160-9545-00	671-2855-00			IC,MEMORY:CMOS,PROM;8K X 8,40NS,REGISTERED	80009	160954500
A2U22	160-9545-00	671-2856-00			IC,MEMORY:CMOS,PROM;8K X 8,40NS,REGISTERED	80009	160954500
A2U22	163-0272-00	671-3485-00			IC,MEMORY:CMOS,PROM;8K X 8,40NS,REGISTERED	80009	163-0272-00
A2U22	163-0272-00	671-3531-00			IC,MEMORY:CMOS,PROM;8K X 8,40NS,REGISTERED (OPT 01; OPT 01 & 02; OPT 01, 02, & 10 ONLY)	80009	163-0272-00
	136-1038-00				*MOUNTING PARTS* SOCKET,DIP:PCB;STR,28 POS,2 X 14,0.1X 0.3CTR,0.185 H X 0.130 TAIL,TIN,BD RETENTION,BECU	00779	2-382571-1
					END MOUNTING PARTS		
A2U24	160-9546-00	671-2855-00			IC,MEMORY:CMOS,PROM;8K X 8,40NS,REGISTERED	80009	160954600
A2U24	160-9546-00	671-2856-00			IC,MEMORY:CMOS,PROM;8K X 8,40NS,REGISTERED	80009	160954600
A2U24	163-0273-00	671-3485-00			IC,MEMORY:CMOS,PROM;8K X 8,40NS,REGISTERED	80009	163-0273-00
A2U24	163-0273-00	671-3531-00			IC,MEMORY:CMOS,PROM;8K X 8,40NS,REGISTERED (OPT 01; OPT 01 & 02; OPT 01, 02, & 10 ONLY)	80009	163-0273-00
	136-1038-00				*MOUNTING PARTS* SOCKET,DIP:PCB;STR,28 POS,2 X 14,0.1X 0.3CTR,0.185 H X 0.130 TAIL,TIN,BD RETENTION,BECU	00779	2-382571-1
					END MOUNTING PARTS		
A2U26	160-9547-00	671-2855-00			IC,MEMORY:CMOS,PROM;8K X 8,40NS	80009	160954700
A2U26	160-9547-00	671-2856-00			IC,MEMORY:CMOS,PROM;8K X 8,40NS	80009	160954700
A2U26	163-0274-00	671-3485-00			IC,MEMORY:CMOS,PROM;8K X 8,40NS,REGISTERED	80009	163-0274-00
A2U26	163-0274-00	671-3531-00			IC,MEMORY:CMOS,PROM;8K X 8,40NS,REGISTERED (OPT 01; OPT 01 & 02; OPT 01, 02, & 10 ONLY)	80009	163-0274-00
	136-1038-00				*MOUNTING PARTS* SOCKET,DIP:PCB;STR,28 POS,2 X 14,0.1X 0.3CTR,0.185 H X 0.130 TAIL,TIN,BD RETENTION,BECU	00779	2-382571-1
					END MOUNTING PARTS		
A2U28	160-9548-00	671-2855-00			IC,MEMORY:CMOS,PROM;8K X 8,40NS	80009	160954800
A2U28	160-9548-00	671-2856-00			IC,MEMORY:CMOS,PROM;8K X 8,40NS	80009	160954800
A2U28	163-0275-00	671-3485-00			IC,MEMORY:CMOS,PROM;8K X 8,40NS,REGISTERED	80009	163-0275-00
A2U28	163-0275-00	671-3531-00			IC,MEMORY:CMOS,PROM;8K X 8,40NS,REGISTERED (OPT 01; OPT 01 & 02; OPT 01, 02, & 10 ONLY)	80009	163-0275-00
	136-1038-00				*MOUNTING PARTS* SOCKET,DIP:PCB;STR,28 POS,2 X 14,0.1X 0.3CTR,0.185 H X 0.130 TAIL,TIN,BD RETENTION,BECU	00779	2-382571-1
					END MOUNTING PARTS		
A2U29	156-3019-00				IC,LINEAR:BIPOLAR,VOLTAGE REFERENCE;1.235V, 1.0%,150PPM,SHUNT,MICROPOWER	27014	LM385BZ-1.2
A2U31	156-6376-00				IC,CONVERTER:BIPOLAR,D/A;12-BIT,20MHZ,2LSB, CURRENT OUT,LATCHED	07933	TDC1012R3C1
					MOUNTING PARTS		

Replaceable Electrical Parts

Reference designator	Tektronix part number	Serial / Assembly number		Name & description	Mfr. code	Mfr. part number
		Effective	Discontinued			
	136-1005-00			SOCKET,PLCC:PCB;28 POS,0.05 CTR,0.360H X 0.125 TAIL,TIN,0.055-0.075 IC SHOULDER *END MOUNTING PARTS*	00779	3-821581-1
A2U50	156-0872-00			IC,LINAR:BIPOLAR,VR;NEGATIVE,-12V,1.0A,4%	01295	UA7912CKC
A2U102	160-9549-00	671-2855-00		IC,MEMORY:CMOS;EPROM,256K X 8,200NS	80009	160954900
A2U102	160-9549-00	671-2856-00		IC,MEMORY:CMOS;EPROM,256K X 8,200NS	80009	160954900
A2U102	163-0270-00	671-3485-00		IC,MEMORY:CMOS,EPROM,256K X 8,200NS,27C020, DIP32.6	80009	163-0270-00
A2U102	163-0270-00	671-3531-00		IC,MEMORY:CMOS,EPROM,256K X 8,200NS,27C020, DIP32.6 (OPT 01; OPT 01 & 02; OPT 01, 02, & 10 ONLY) *MOUNTING PARTS*	80009	163-0270-00
	136-0963-00			SOCKET,DIP:PCB;32,2 X 16,0.1 X 0.6 CTR,0.210 H X 0.12 TAIL,PHOS BRZ,ACCOM 0.008-0.014 THICK LEAD,DUAL *END MOUNTING PARTS*	00779	2-644018-3
A2U104	160-9550-00	671-2855-00		IC,MEMORY:CMOS;EPROM,256K X 8,200NS	80009	160955000
A2U104	160-9550-00	671-2856-00		IC,MEMORY:CMOS;EPROM,256K X 8,200NS	80009	160955000
A2U104	163-0270-00	671-3485-00		IC,MEMORY:CMOS,EPROM,256K X 8,200NS,27C020, DIP32.6	80009	163-0270-00
A2U104	163-0270-00	671-3531-00		IC,MEMORY:CMOS,EPROM,256K X 8,200NS,27C020, DIP32.6 (OPT 01; OPT 01 & 02; OPT 01, 02, & 10 ONLY) *MOUNTING PARTS*	80009	163-0270-00
	136-0963-00			SOCKET,DIP:PCB;32,2 X 16,0.1 X 0.6 CTR,0.210 H X 0.12 TAIL,PHOS BRZ,ACCOM 0.008-0.014 THICK LEAD,DUAL *END MOUNTING PARTS*	00779	2-644018-3
A2U106	156-0368-03			IC,DIGITAL:ECL,TRANSLATOR;QUAD TTL-TO-ECL	04713	MC10124P
A2U108	156-0316-04			IC,DIGITAL:ECL,TRANSLATOR;QUAD ECL TOTTL	04713	MC10125P
A2U150	156-3120-00			IC,DIGITAL:FCTCMOS,FLIP FLOP;OCTAL D-TYPE,3-STATE *MOUNTING PARTS*	27014	74FCT374APC
	136-0752-00			SKT,PL-IN ELEK;MICROCIRCUIT,20 DIP *END MOUNTING PARTS*	09922	DILB20P-108
A2U200	156-4104-00			IC,LINAR:BIPOLAR,SW-REGULATOR CONTROL- LER;PWM, CURRENT MODE,SINGLE TOTEM POLE OUTPUT	48726	UC3843N
A2U201	160-9749-00	671-2855-00		IC,DIGITAL:CMOS,PLD;OTP;5064,64 MACROCELL,30NS	80009	160974900
A2U201	160-9749-00	671-2856-00		IC,DIGITAL:CMOS,PLD;OTP;5064,64 MACROCELL,3	80009	160974900
A2U201	163-0269-00	671-3485-00		IC,DIGITAL:CMOS,PLD;OTP;5064,64 M/C,28 I/O,8 IN,30 NS	80009	163-0269-00
A2U201	163-0269-00	671-3531-00		IC,DIGITAL:CMOS,PLD;OTP;5064,64 M/C,28 I/O,8 IN,30 NS (OPT 01; OPT 01 & 02; OPT 01, 02, & 10 ONLY) *MOUNTING PARTS*	80009	163-0269-00
	136-1047-00			SOCKET,PLCC:PCB;44 POS,0.05 CTR,0.360H X 0.125 TAIL,TIN *END MOUNTING PARTS*	00779	821575-1
A2U202	160-9551-00			IC,DIGITAL:CMOS,PLD;OTP;5064,64 MACROCELL,30NS *MOUNTING PARTS*	80009	160955100
	136-1047-00			SOCKET,PLCC:PCB;44 POS,0.05 CTR,0.360H X 0.125 TAIL,TIN *END MOUNTING PARTS*	00779	821575-1
A2U212	156-1160-00			IC,LINAR:BIPOLAR,VOLTAGE REGULATOR;POSITIV E,12V,100MA,4%	27014	LM78L12ACH
A2U220	156-2338-00			IC,DIGITAL:ASTTL,FLIP FLOP;DUAL D-TYPE	01295	SN74AS74N
A2U222	156-3156-00			IC,LIN:CMOS,DGTL QUADRATURE MXR/MOD;TMC2249, PGA120	07933	TMC2249H5C

Reference designator	Tektronix part number	Serial / Assembly number		Name & description	Mfr. code	Mfr. part number
		Effective	Discontinued			
A2U225	156-4170-00	B020610		IC,LINEAR:BIPOLAR,OP-AMP,CURRENT FEEDBACK,100MHZ,HIGH OUTPUT CURRENT,OPA603AP,DIP08.3	13919	OPA603AP
A2U227	156-3019-00	B020610		IC,LINEAR:BIPOLAR,VOLTAGE REFERENCE,1.235V,1.0%,150PPM,SHUNT,MICROPOWER,LM385BZ-1.2,TO-92	27014	LM385BZ-1.2
	136-0904-00			*MOUNTING PARTS* SOCKET,PGA:PCB;121 POS,13 X 13,0.1 X 0.1 CTR,0.250 H X 0.110 TAIL,TIN,NON-SYMMETRICAL,PAT 1313	00779	916223-2 (PKG B
				END MOUNTING PARTS		
A2U228	160-9409-00			IC,MEMORY:	80009	160940900
A2U229	160-9410-00			IC,MEMORY:	80009	160941000
A2U235	156-3156-00	B020610		IC,LINEAR:CMOS,DIGITAL QUADRATURE MIXER/MODULATOR,TMC2249,PGA120	07933	TMC2249H5C
	136-0904-00	B020610		**ATTACHING PARTS** SOCKET,PGA:PCB,121 POS,13 X 13,0.1 X 0.1 CTR,0.250 H X 0.110 TAIL,TIN,NON-SYMMETRICAL,PAT	00779	916223-2 (PKG B)
				END ATTACHING PARTS		
A2U236	156-6229-00	B020610		IC,DIGITAL:CMOS,PLD,OTP,MAX 5000 FAMILY,5064,64 M/C,28 I/O,8 IN,30NS,EP5064-30,PLCC44,TUBE	65786	CY7C343-30JC
	136-1047-00	B020610		**ATTACHING PARTS** SOCKET,PLCC:PCB,44 POS,0.05 CTR,0.360 H X 0.125 TAIL,TIN,	00779	821575-1
				END ATTACHING PARTS		
A2U238	156-6376-00	B020610		IC,CONVERTER:BIPOLAR,D/A,12-BIT,20MHZ,2LSB,CURRENT OUT,LATCHED,TDC1012RSC1,PLCC28.3	07933	TDC1012R3C1
	136-1005-00	B020610		**ATTACHING PARTS** SOCKET,PLCC:PCB,28 POS,0.05 CTR,0.360 H X 0.125 TAIL,TIN,0.055-0.075 IC SHOULDER,TUBE/18 EA	00779	3-821581-1
				END ATTACHING PARTS		
A2U240	156-3120-00			IC,DIGITAL:FCTCMOS,FLIP FLOP;OCTAL D-TYPE,3-STATE	27014	74FCT374APC
A2U245	160-9552-00			IC,DIGITAL:CMOS,PLD:OTP,5064,64 MACROCELL,30NS	80009	160955200
A2UY1	119-4282-00			XTAL UNIT:QTZ,17.734375 MHZ,0.5 PPM,TUNE RANGE 5PPM (OPT 01: OPT 01 & 02; OPT 01, 02, & 10 ONLY)	80009	119428200
A2W155	131-4566-00			BUS,CONDUCTOR:0 OHM,300 SPACING,SM BODY-MI,DUMMY RES	91637	FRJ-50
A2W156	131-4566-00			BUS,CONDUCTOR:0 OHM,300 SPACING,SM BODY-MI,DUMMY RES	91637	FRJ-50
A2W157	131-4566-00			BUS,CONDUCTOR:0 OHM,300 SPACING,SM BODY-MI,DUMMY RES	91637	FRJ-50
A2W158	131-4566-00			BUS,CONDUCTOR:0 OHM,300 SPACING,SM BODY-MI,DUMMY RES	91637	FRJ-50
A2W159	131-4566-00			BUS,CONDUCTOR:0 OHM,300 SPACING,SM BODY-MI,DUMMY RES	91637	FRJ-50
A2W166	131-4566-00			BUS,CONDUCTOR:0 OHM,300 SPACING,SM BODY-MI,DUMMY RES	91637	FRJ-50
A2W167	131-4566-00			BUS,CONDUCTOR:0 OHM,300 SPACING,SM BODY-MI,DUMMY RES	91637	FRJ-50
A2W168	131-4566-00			BUS,CONDUCTOR:0 OHM,300 SPACING,SM BODY-MI,DUMMY RES	91637	FRJ-50
A2W169	131-4566-00			BUS,CONDUCTOR:0 OHM,300 SPACING,SM BODY-MI,DUMMY RES	91637	FRJ-50
A2W179	131-4566-00			BUS,CONDUCTOR:0 OHM,300 SPACING,SM BODY-MI,DUMMY RES	91637	FRJ-50
A2W180	131-4566-00			BUS,CONDUCTOR:0 OHM,300 SPACING,SM BODY-MI,DUMMY RES	91637	FRJ-50

Replaceable Electrical Parts

Reference designator	Tektronix part number	Serial / Assembly number		Name & description	Mfr. code	Mfr. part number
		Effective	Discontinued			
A2W181	131-4566-00			BUS,CONDUCTOR:0 OHM,300 SPACING,SM BODY-MI,DUMMY RES	91637	FRJ-50
A2W183	131-4566-00	B020610		BUS,CONDUCTOR:0 OHM,300 SPACING,SM BODY MI,DUMMY RES	91637	FRJ-50
A2Y1	119-4281-00	671-2855-00		XTAL UNIT,QTZ:17.734375MHZ,1PPM,TCXO,TUNE RANGE 5PPM,TTL,PKG 1.5 SQX 0.7 HIGH	82567	03-02155-016
A2Y1	119-4282-00	671-2856-00		XTAL UNIT,QTZ:17.734375MHZ,0.5PPM,TCXO,TUNE	82567	03-03186-001
A2Y1	119-4282-00	671-3485-00		XTAL UNIT,QTZ:17.734375MHZ,0.5PPM,TCXO,TUNE	82567	03-03186-001
A2Y1	119-4282-00	671-3531-00		XTAL UNIT,QTZ:17.734375MHZ,0.5PPM,TCXO,TUNE	82567	03-03186-001
A2CR10	152-0601-01			DIODE,RECT:ULTRA FAST;150V,25NS,35A IFSM	04713	MUR115RL
A2CR11	152-0601-01			DIODE,RECT:ULTRA FAST;150V,25NS,35A IFSM	04713	MUR115RL
A2CR12	152-0601-01			DIODE,RECT:ULTRA FAST;150V,25NS,35A IFSM	04713	MUR115RL
A2CR13	152-0601-01			DIODE,RECT:ULTRA FAST;150V,25NS,35A IFSM	04713	MUR115RL
A2CR40	152-0601-01			DIODE,RECT:ULTRA FAST;150V,25NS,35A IFSM	04713	MUR115RL
A2CR50	152-0601-01			DIODE,RECT:ULTRA FAST;150V,25NS,35A IFSM	04713	MUR115RL
A2CR60	152-0670-00			DIODE,RECT:SCHTKY;40V,3A,IFSM=80A,VF=525MV	04713	1N5822
A2CR70	152-0670-00			DIODE,RECT:SCHTKY;40V,3A,IFSM=80A,VF=525MV	04713	1N5822
A2CR71	152-0670-00			DIODE,RECT:SCHTKY;40V,3A,IFSM=80A,VF=525MV	04713	1N5822
A2CR80	152-0066-00			DIODE,RECT:;400V,1A,IFSM=30A,1.2VF,2US	0LUA3	1N5060
A2CR81	152-0676-00			DIODE,RECT:;400V,3A,125A IFSM,1VF AT3A	13409	SEN-R-247 (1N56
A2CR85	152-0141-02			DIODE,SIG:ULTRA FAST;40V,150MA,4NS,2PF	27014	FDH9427
A2FL2	119-4316-00			FILTER,LOWPASS:PCB,SIP;DELAY EQUALIZED,6MHZ	19615	F4105
A2LF1	119-1946-00			FILTER,RFI:1A,250V,400HZ W/PC TERMINAL	0GV52	FN326-1/02-K-D-
A2TP1	214-4085-00			TERM,TEST POINT:0.070 ID,0.220 H,0.063 DIAP CB,0.015 X 0.032 BRASS,W/RED NYLON COLLAR	26364	104-01-02
A2TP5	214-4085-00			TERM,TEST POINT:0.070 ID,0.220 H,0.063 DIAP CB,0.015 X 0.032 BRASS,W/RED NYLON COLLAR	26364	104-01-02
A2TP8	214-4085-00			TERM,TEST POINT:0.070 ID,0.220 H,0.063 DIAP CB,0.015 X 0.032 BRASS,W/RED NYLON COLLAR	26364	104-01-02
A2TP9	214-4085-00			TERM,TEST POINT:0.070 ID,0.220 H,0.063 DIAP CB,0.015 X 0.032 BRASS,W/RED NYLON COLLAR	26364	104-01-02
A2TP10	214-4085-00			TERM,TEST POINT:0.070 ID,0.220 H,0.063 DIAP CB,0.015 X 0.032 BRASS,W/RED NYLON COLLAR	26364	104-01-02
A2TP13	214-4085-00			TERM,TEST POINT:0.070 ID,0.220 H,0.063 DIAP CB,0.015 X 0.032 BRASS,W/RED NYLON COLLAR	26364	104-01-02
A2TP17	214-4085-00			TERM,TEST POINT:0.070 ID,0.220 H,0.063 DIAP CB,0.015 X 0.032 BRASS,W/RED NYLON COLLAR	26364	104-01-02
A2VR30	152-0520-00			DIODE,ZENER:12V,5%,1W	12954	DZ840631L
A3	671-2290-01			CIRCUIT BD ASSY:TOP BNC	80009	671229001
A3J401	131-3378-00			CONN,RF JACK:BNC:50 OHM,FEMALE,RTANG,PCB/ REAR PNL,0.5-28 THD,0.625 H X 0.187 TAIL,W/O	00779	227677-1
A3J404	131-3378-00			CONN,RF JACK:BNC:50 OHM,FEMALE,RTANG,PCB/ REAR PNL,0.5-28 THD,0.625 H X 0.187 TAIL,W/O	00779	227677-1
A3J405	131-0608-00			CONN,TERMINAL:PRESSFIT/ PCB;MALE,STR,0.025SQ,0.248 MLG X 0.137 TAIL,50 GOLD,PHZ BRZ,W/FERRULE (QUANTITY 16)	22526	48283-018
A3W405	174-2966-00			CA ASSY,SP,ELEC:RIBBON;IDC,16,28 AWG,1.9 L,2X8,0.1 CTR,RECPT BOTH ENDS,ACCOM 0.L025 SQ PIN	TK1547	174-2966-00
A4	671-2291-01			CIRCUIT BD ASSY:BOTTOM BNC	80009	671229101
A4J501	131-3378-00			CONN,RF JACK:BNC:50 OHM,FEMALE,RTANG,PCB/ REAR PNL,0.5-28 THD,0.625 H X 0.187 TAIL,W/O	00779	227677-1

Reference designator	Tektronix part number	Serial / Assembly number Effective	Discontinued	Name & description	Mfr. code	Mfr. part number
A4J505	131-0608-00			CONN,TERMINAL:PRESSFIT/ PCB;MALE,STR,0.025SQ,0.248 MLG X 0.137 TAIL,50 GOLD,PHZ BRZ,W/FERRULE (QUANTITY 10)	22526	48283-018
A4W505	174-2967-00			CA ASSY,SP,ELEC:RIBBON:IDC,10,28 AWG,1.6 L,2X5,0.1 CTR,RECPT BOTH ENDS,ACCOM 0.025 SQ	TK1547	174-2967-00
A5	671-2976-00		B029999	CIRCUIT BD ASSY:AUDIO	80009	671297600
A5	671-2976-01	B030000		CIRCUIT BD ASSY:AUDIO	80009	671297601
A5C4	281-0775-01			CAP,FXD,CERAMIC:MCL:0.1UF,20%,50V,Z5U,0.170	04222	SA105E104MAA
A5C81	281-0775-01			CAP,FXD,CERAMIC:MCL:0.1UF,20%,50V,Z5U,0.170	04222	SA105E104MAA
A5C83	281-0775-01			CAP,FXD,CERAMIC:MCL:0.1UF,20%,50V,Z5U,0.170	04222	SA105E104MAA
A5C84	281-0775-01			CAP,FXD,CERAMIC:MCL:0.1UF,20%,50V,Z5U,0.170	04222	SA105E104MAA
A5C85	281-0775-01			CAP,FXD,CERAMIC:MCL:0.1UF,20%,50V,Z5U,0.170	04222	SA105E104MAA
A5C86	281-0775-01			CAP,FXD,CERAMIC:MCL:0.1UF,20%,50V,Z5U,0.170	04222	SA105E104MAA
A5C110	283-0594-02			CAP,FXD,MICA DI:1000PF,1%,100V,TAPE & AMMOPACK	09023	CDA15FA102F03
A5C111	283-0594-02			CAP,FXD,MICA DI:1000PF,1%,100V,TAPE & AMMOPACK	09023	CDA15FA102F03
A5C112	283-0177-05			CAP,FXD,CER DI:1UF,+80-20%,25V	04222	SR303E105ZAAAP1
A5C113	281-0775-01			CAP,FXD,CERAMIC:MCL:0.1UF,20%,50V,Z5U,0.170	04222	SA105E104MAA
A5C114	290-1313-00			CAP,FXD,ALUM:10UF,20%,50V,8 X 11MM;105 DEG,RDL,T&A	55680	UET1H100MPH1TA
A5C150	290-1313-00			CAP,FXD,ALUM:10UF,20%,50V,8 X 11MM;105 DEG,RDL,T&A	55680	UET1H100MPH1TA
A5C259	281-0777-00			CAP,FXD,CERAMIC:MLC:51PF,5%,200V,0.100 X 0.170	04222	SA102A510JAA
A5C260	281-0777-00			CAP,FXD,CERAMIC:MLC:51PF,5%,200V,0.100 X 0.170	04222	SA102A510JAA
A5C261	281-0777-00			CAP,FXD,CERAMIC:MLC:51PF,5%,200V,0.100 X 0.170	04222	SA102A510JAA
A5C262	281-0777-00			CAP,FXD,CERAMIC:MLC:51PF,5%,200V,0.100 X 0.170	04222	SA102A510JAA
A5C350	281-0775-01			CAP,FXD,CERAMIC:MCL:0.1UF,20%,50V,Z5U,0.170	04222	SA105E104MAA
A5C351	290-0943-02			CAP,FXD,ELCTL:47UF,20%,25VTAPED & REELED	55680	UVX1E470MDA1TD
A5C352	290-0943-02			CAP,FXD,ELCTL:47UF,20%,25VTAPED & REELED	55680	UVX1E470MDA1TD
A5FL4	119-4225-00	671-2976-01		FILTER,EMI: T-CIRCUIT;25 MHZ CUTOFF, INS LOSS 25DB@100-1000MHZ, C 0.5A,50V,180PF,70OHM;094T X.295WX.315H;SIP, RADIAL	TK2058	ZJSC-R47-181-TA
A5FL3	119-4225-00	671-2976-01		FILTER,EMI: T-CIRCUIT;25 MHZ CUTOFF, INS LOSS 25DB@100-1000MHZ, C 0.5A,50V,180PF,70OHM;094T X.295WX.315H;SIP, RADIAL	TK2058	ZJSC-R47-181-TA
A5FL2	119-4225-00	671-2976-01		FILTER,EMI: T-CIRCUIT;25 MHZ CUTOFF, INS LOSS 25DB@100-1000MHZ, C 0.5A,50V,180PF,70OHM;094T X.295WX.315H;SIP, RADIAL	TK2058	ZJSC-R47-181-TA
A5FL1	119-4225-00	671-2976-01		FILTER,EMI: T-CIRCUIT;25 MHZ CUTOFF, INS LOSS 25DB@100-1000MHZ, C 0.5A,50V,180PF,70OHM;094T X.295WX.315H;SIP, RADIAL	TK2058	ZJSC-R47-181-TA
A5J9	131-3987-00			CONN,CIRC:PCB,AUDIO;MALE,RTANG,3 POS,1.22H X 1.024 W,CTR PLZ,LATCHING *MOUNTING PARTS*	0FMA6	NC3MD-H
	213-0055-00			SCREW,TPG,TF:2-32 X 0.188,TYPE B,PNH,STL *END MOUNTING PARTS*	TK0435	ORDER BY DESC
A5J10	131-3987-00			CONN,CIRC:PCB,AUDIO;MALE,RTANG,3 POS,1.22H X 1.024 W,CTR PLZ,LATCHING *MOUNTING PARTS*	0FMA6	NC3MD-H
	213-0055-00			SCREW,TPG,TF:2-32 X 0.188,TYPE B,PNH,STL *END MOUNTING PARTS*	TK0435	ORDER BY DESC
A5J12	131-1426-00			CONN,HDR:PCB;MALE,RTANG,1 X 36,0.1CTR,0.23	22526	65524-136

Replaceable Electrical Parts

Reference designator	Tektronix part number	Serial / Assembly number		Name & description	Mfr. code	Mfr. part number
		Effective	Discontinued			
A5J128	131-0608-00			CONN,TERMINAL:PRESSFIT/ PCB;MALE,STR,0.025SQ,0.248 MLG X 0.137 TAIL,50 GOLD,PHZ BRZ,W/FERRULE (QUANTITY 10)	22526	48283-018
A5P12	131-0993-05			BUS,CONDUCTOR:SHUNT ASSEMBLY,GREEN	00779	850100-5
A5Q1	151-1045-00			XSTR,SIG:JFET,P-CH:4.5V(SELECTED),5MA,1MS,GEN- ERAL	66182	SPJ3226
A5Q2	151-1025-00			XSTR,SIG:JFET,N-CH:6V,15MA,4.5MS,AMPL	17856	J304
A5R102	322-3039-00			RES,FXD,FILM:24.9 OHM,1%,0.2W,TC=T0,SMALL BODY	91637	CCF50-2-G24R90F
A5R103	322-3289-00			RES,FXD:METAL FILM;10K OHM,1%,0.2W,TC=100 PPM	91637	CCF50G10001F
A5R104	322-3039-00			RES,FXD,FILM:24.9 OHM,1%,0.2W,TC=T0,SMALL BODY	91637	CCF50-2-G24R90F
A5R105	322-3222-00			RES,FXD:METAL FILM;2K OHM,1%,0.2W,TC=100 PPM	91637	CCF501G20000F
A5R106	322-3404-00			RES,FXD,FILM:158K OHM,1%,0.2W,TC=T0MI,SMALL	91637	CCF50-2F15802F
A5R107	322-3404-00			RES,FXD,FILM:158K OHM,1%,0.2W,TC=T0MI,SMALL	91637	CCF50-2F15802F
A5R108	322-3260-00			RES,FXD,FILM:4.99K OHM,1%,0.2W,TC=T0TAPED &	91637	CCF501G49900F
A5R109	322-3289-00			RES,FXD:METAL FILM;10K OHM,1%,0.2W,TC=100 PPM	91637	CCF50G10001F
A5R110	322-3318-00			RES,FXD:METAL FILM;20K OHM,1%,0.2W,TC=100 PPM	91637	CCF501G20001F
A5R111	322-3453-00			RES,FXD,FILM:511K OHM,1%,0.2W,TC=T0MI,SMALL	91637	CCF50-2F51102F
A5R112	322-3275-00			RES,FXD,FILM:7.15K OHM,1%,0.2W,TC=T0MI,SMALL BODY	91637	CCF501G71500F
A5R113	322-3239-00			RES,FXD,FILM:3.01K OHM,1%,0.2W,TC=T0MI,SMALL BODY	91637	CCF501G30100F
A5R114	322-3409-00			RES,FXD,FILM:178K OHM,1%,0.2W,TC=T0MI,SMALL	91637	CCF50G17802F
A5R115	322-3039-00			RES,FXD,FILM:24.9 OHM,1%,0.2W,TC=T0,SMALL BODY	91637	CCF50-2-G24R90F
A5R116	322-3289-00			RES,FXD:METAL FILM;10K OHM,1%,0.2W,TC=100 PPM	91637	CCF50G10001F
A5R117	322-3039-00			RES,FXD,FILM:24.9 OHM,1%,0.2W,TC=T0,SMALL BODY	91637	CCF50-2-G24R90F
A5R118	322-3289-00			RES,FXD:METAL FILM;10K OHM,1%,0.2W,TC=100 PPM	91637	CCF50G10001F
A5R119	322-3289-00			RES,FXD:METAL FILM;10K OHM,1%,0.2W,TC=100 PPM	91637	CCF50G10001F
A5R120	322-3239-00			RES,FXD,FILM:3.01K OHM,1%,0.2W,TC=T0MI,SMALL BODY	91637	CCF501G30100F
A5R121	322-3280-00			RES,FXD,FILM:8.06K OHM,1%,0.2W,TC=T0MI,SMALL BODY	91637	CCF501G80600F
A5R122	311-2269-00			RES,VAR,NONWWW:TRMR,20K OHM,20%,0.5WLINEAR,MI	TK2073	GF06VT2 203 M L
A5R123	311-2269-00			RES,VAR,NONWWW:TRMR,20K OHM,20%,0.5WLINEAR,MI	TK2073	GF06VT2 203 M L
A5R124	322-3193-00			RES,FXD:METAL FILM;1K OHM,1%,0.2W,TC=100 PPM	91637	CCF501G10000F
A5R125	322-3326-00			RES,FXD,FILM:24.3K OHM,1%,0.2W,TC=T0MI,SMALL BODY	91637	CCF50-2F24301F
A5R126	311-2262-00			RES,VAR,NONWWW:TRMR,1M OHM,20%,0.5WLINEAR,MI	TK2073	GF06VT2 105 M L
A5R127	322-3226-00			RES,FXD:METAL FILM;2.21K OHM,1%,0.2W,TC=100	91637	CCF501G22100F
A5R150	322-3260-00			RES,FXD,FILM:4.99K OHM,1%,0.2W,TC=T0TAPED &	91637	CCF501G49900F
A5R151	322-3260-00			RES,FXD,FILM:4.99K OHM,1%,0.2W,TC=T0TAPED &	91637	CCF501G49900F
A5R152	322-3260-00			RES,FXD,FILM:4.99K OHM,1%,0.2W,TC=T0TAPED &	91637	CCF501G49900F
A5R153	322-3260-00			RES,FXD,FILM:4.99K OHM,1%,0.2W,TC=T0TAPED &	91637	CCF501G49900F
A5R209	321-0673-07			RES,FXD,FILM:17K OHM,0.1%,0.125W,TC=T9MI	19701	5033RE17K00B
A5R210	321-0962-07			RES,FXD,FILM:8K OHM,0.1%,0.125W,TC=T9	57027	8.0K
A5U40	156-1291-00			IC,LINEAR:BIFET,OP-AMP;DUAL,LOW POWER	01295	TL062CP
A5U41	156-1272-00			IC,LINEAR:BIPOLAR,OP-AMP;DUAL,HIGH OUTPUT DRIVE,LOW NOISE	01295	NE5532P
A5U42	156-1272-00			IC,LINEAR:BIPOLAR,OP-AMP;DUAL,HIGH OUTPUT DRIVE,LOW NOISE	01295	NE5532P
A5U43	156-0402-00			IC,MISC:BIPOLAR,TIMER	27014	LM555CN
A5W128	174-2967-00			CA ASSY,SP,ELEC:RIBBON;IDC,10,28 AWG,1.6 L,2X5,0.1 CTR,RECPT BOTH ENDS,ACCOM 0.025 SQ	TK1547	174-2967-00
A5W129	131-4566-00			BUS,CONDUCTOR:0 OHM,300 SPACING,SM BODY- MI,DUMMY RES	91637	FRJ-50

Reference designator	Tektronix part number	Serial / Assembly number		Name & description	Mfr. code	Mfr. part number
		Effective	Discontinued			
A5W130	131-4566-00			BUS,CONDUCTOR:0 OHM,300 SPACING,SM BODY-MI,DUMMY RES	91637	FRJ-50
A5CR1	152-0141-02			DIODE,SIG:ULTRA FAST;40V,150MA,4NS,2PF	27014	FDH9427
A5CR2	152-0141-02			DIODE,SIG:ULTRA FAST;40V,150MA,4NS,2PF	27014	FDH9427
A5TP12	214-4085-00			TERM,TEST POINT:0.070 ID,0.220 H,0.063 DIAP CB,0.015 X 0.032 BRASS,W/RED NYLON COLLAR	26364	104-01-02



Diagrams

Diagrams/Circuit Board Illustrations

Symbols

Graphic symbols and class designation letters are based on ANSI Standard Y32.2–1975.

Logic symbology is based on ANSI Y32.14–1973 in terms of positive logic. Logic symbols depict the logic function performed and may differ from the manufacturer’s data.

Overline, parenthesis, or leading slash indicate a low asserting state.

Example: ID CONTROL, (ID CONTROL), or /ID CONTROL.

Abbreviations are based on ANSI Y1.1–1972.

Other ANSI standards that are used in the preparation of diagrams by Tektronix, Inc. are:

Y14.15, 1966 -- Drafting Practices.

Y14.2, 1973 -- Line Conventions and Lettering.

Y10.5, 1968 -- Letter Symbols for Quantities Used in Electrical Science and Electrical Engineering.

American National Standard Institute
1430 Broadway, New York, New York 10018

Component Values

Electrical components shown on the diagrams are in the following units unless noted otherwise:

Capacitors: Values one or greater are in picofarads (pF).

Values less than one are in microfarads (μ F).

Resistors : Ohms (Ω).

The following information and special symbols may appear in this manual.

Assembly Numbers

Each assembly in the instrument is assigned an assembly number (e.g., A20). The assembly number appears on the diagram (in circuit board outline), circuit board illustration title, and lookup table for the schematic diagram.

The Replaceable Electrical Parts List is arranged by assembly number in numerical sequence; the components are listed by component number. Example:

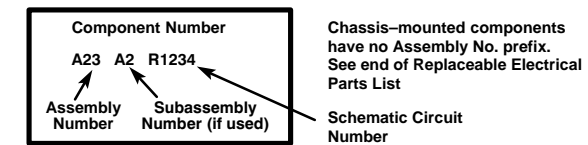

Grid Coordinates

The schematic diagram and circuit board component location illustration have grids. A lookup table with the grid coordinates is provided for ease of locating the component. Only the components illustrated on the facing diagram are listed in the lookup table.

When more than one schematic diagram is used to illustrate the circuitry on a circuit board, the circuit board illustration will only appear opposite the first diagram; the lookup table will list the diagram number of other diagrams that the other circuitry appears on.

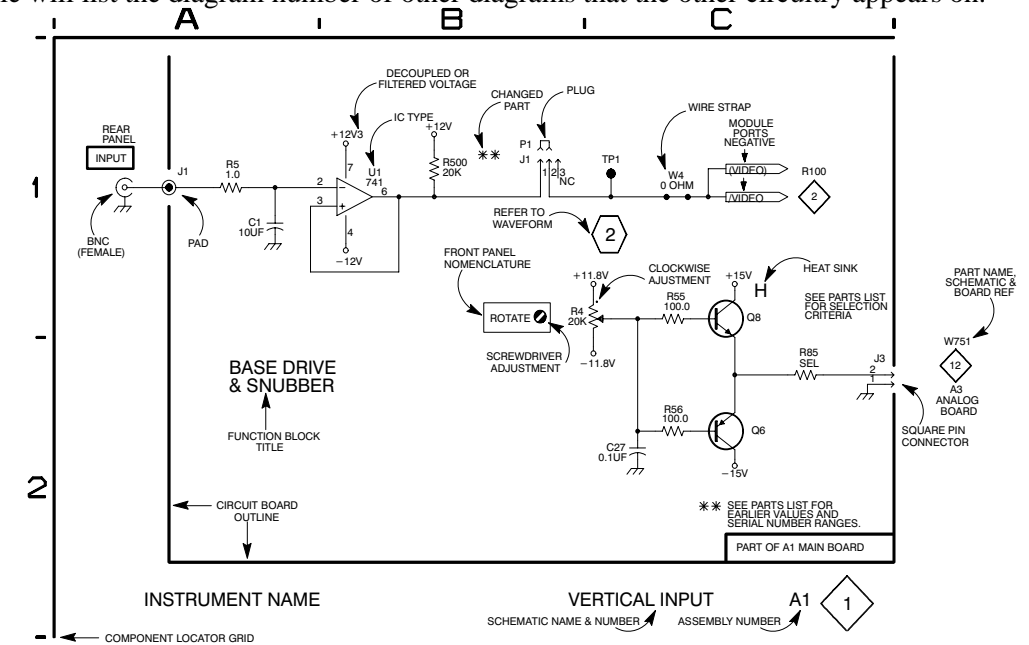

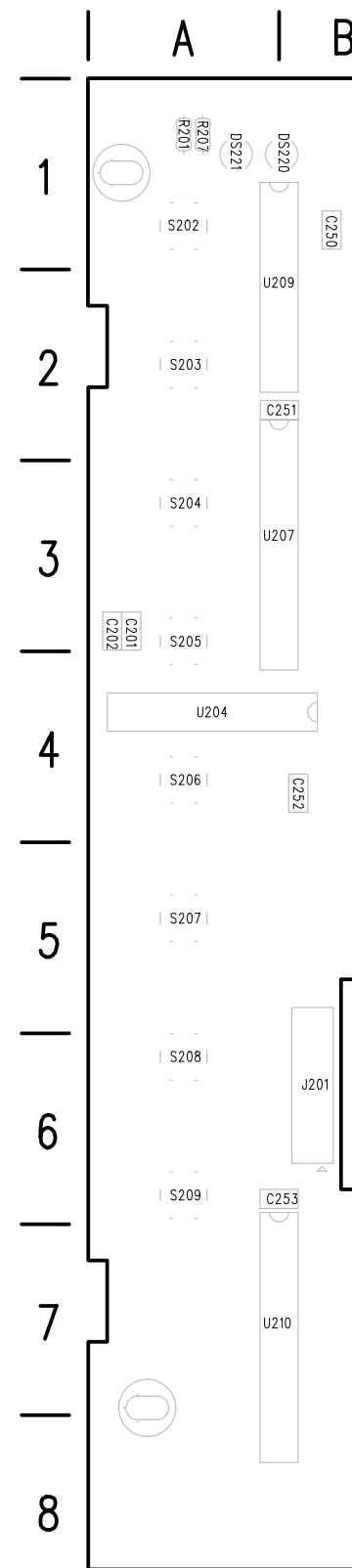

A1 Front Panel Board

**Front Panel Board and
Schematic Diagram <1>
Component Locator Chart**

*The schematic diagram has an
alpha-numeric grid to assist in
locating parts within that diagram.*

Assembly A1

Comp No	Diag Loc	Bd Loc
C201	C2	A3
C202	C2	A3
C250	A1	B1
C251	A1	A2
C252	B1	B4
C253	B1	A6
DS220	H3	B1
DS221	H3	A1
J201	A1	B6
R201	G5	A1
R207	H3	A1
S202A	C4	A1
S202B	C5	A1
S203A	C4	A2
S203B	C5	A2
S204A	D4	A3
S204B	D5	A3
S205A	E4	A3
S205B	E5	A3
S206A	E4	A4
S206B	E5	A4
S207A	F4	A5
S207B	F5	A5
S208A	F4	A6
S208B	G5	A6
S209A	G4	A6
S209B	G5	A6
U204	C2	A4
U207	F3	A3
U209	B5	A2
U210	D2	A7
W201	A1	.

 **Static Sensitive Devices**
See Maintenance Section

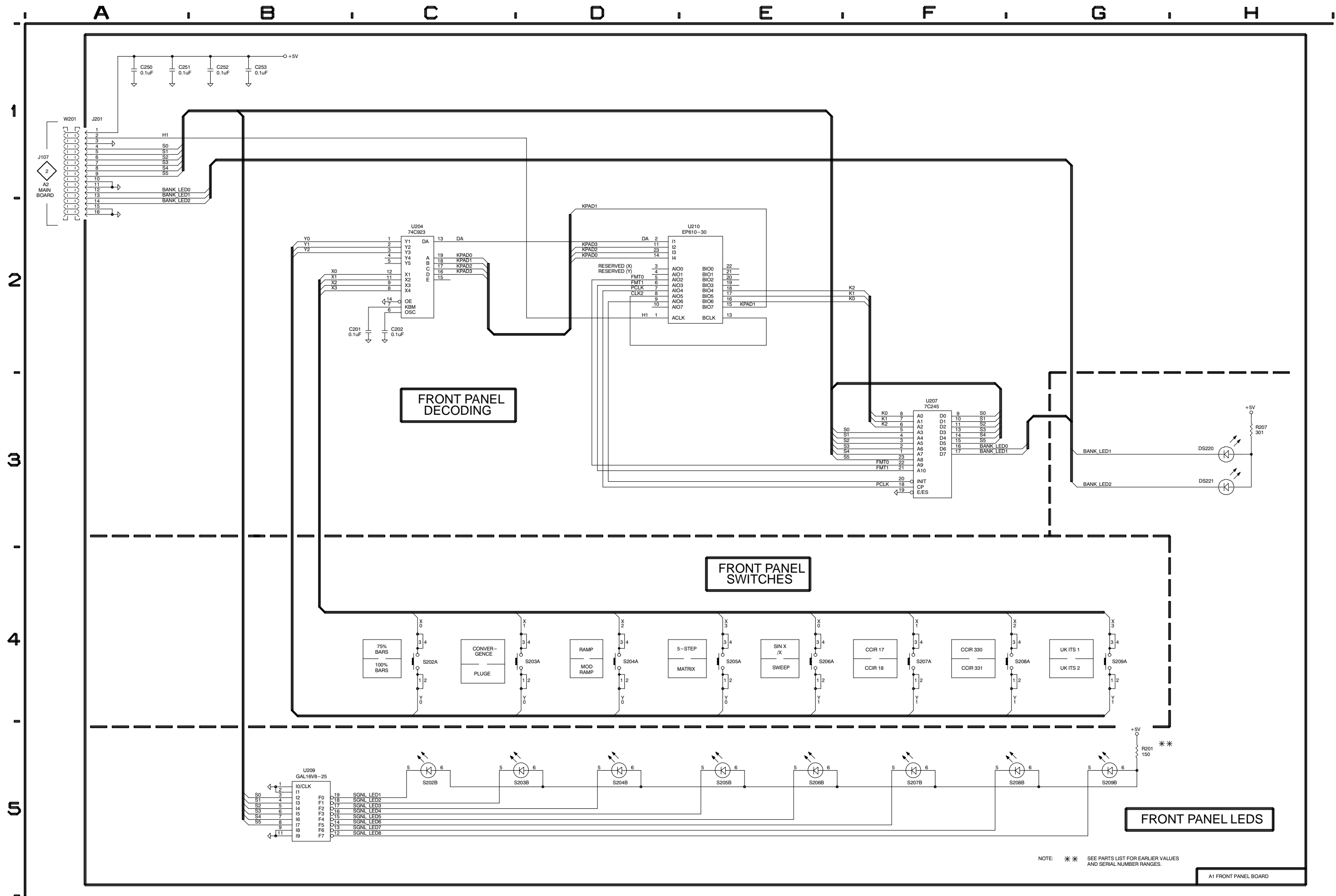

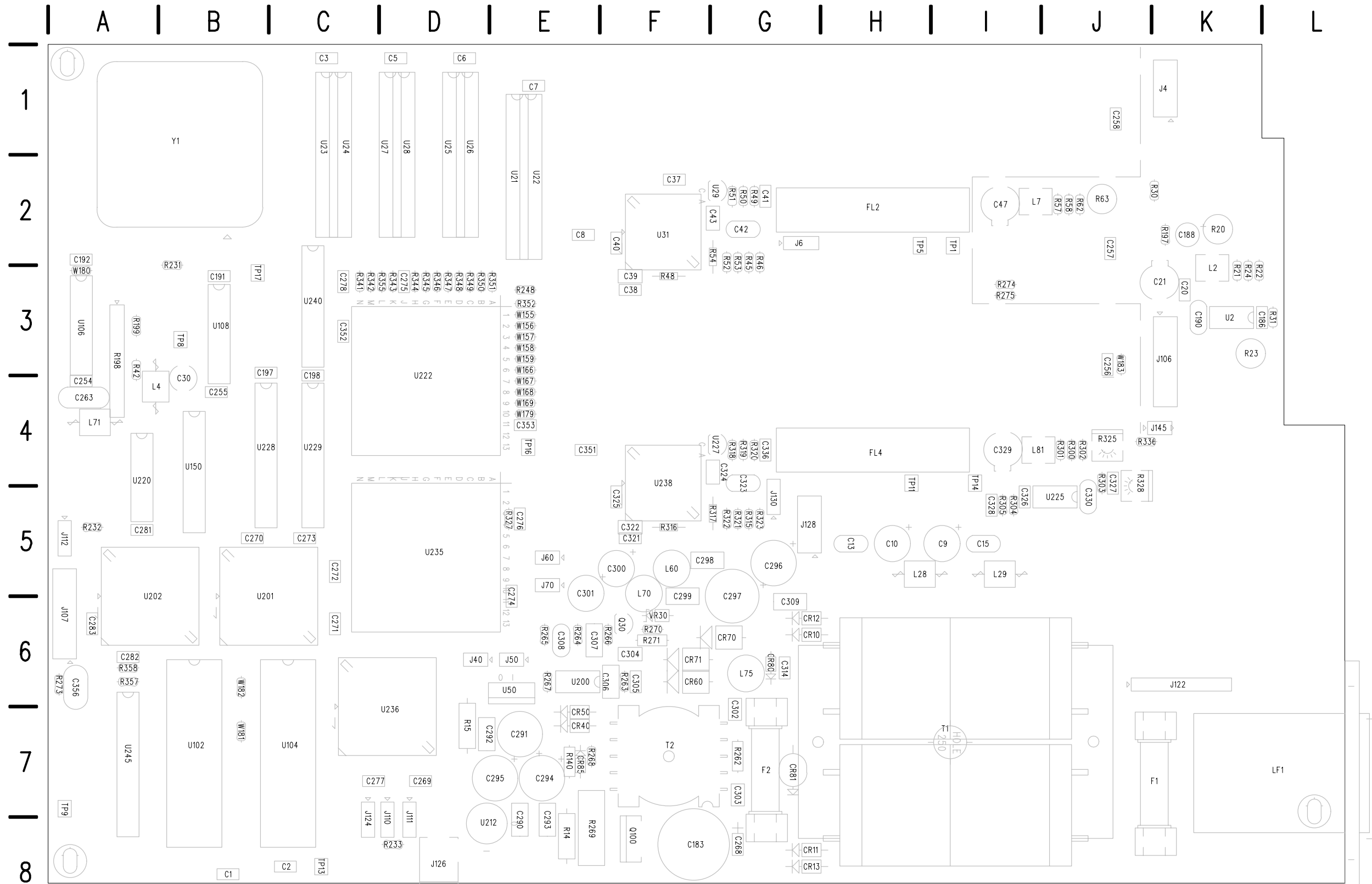

⊗ Static Sensitive Devices
See Maintenance Section

A2 Main Board

A2 Main Board Component Locator (with cross-references to schematic diagrams 2, 3, 4, 5, 8, 9, and 10)

Comp No	Diag No	Diag Loc	Bd Loc	Comp No	Diag No	Diag Loc	Bd Loc	Comp No	Diag No	Diag Loc	Bd Loc	Comp No	Diag No	Diag Loc	Bd Loc	Comp No	Diag No	Diag Loc	Bd Loc	Comp No	Diag No	Diag Loc	Bd Loc	Comp No	Diag No	Diag Loc	Bd Loc	Comp No	Diag No	Diag Loc	Bd Loc	Comp No	Diag No	Diag Loc	Bd Loc									
C1	8	F4	B8	C198	8	G4	C4	C296	8	E3	G5	C353	8	G5	E4	J112	2	A1	A5	P124	2	D3		R232	2	B1	A5	R320	10	B4	G4	TP9	3	A5	A7	U225	10	E3	J5					
C2	8	G4	C8	C254	2	D5	A4	C297	8	E4	G6	C356	2	C3	A6	J122	8	B1	K6	P130	10	C3		R233	2	D1	D8	R321	10	A3	G5	TP10	3	A5	E1	U227	10	B4	G4					
C3	8	G4	C1	C255	2	D5	B4	C298	8	E3	F5	CR10	8	C1	G6	J124	2	D3	C7	Q30	8	C2	F6	R248	4	E3	E3	R322	10	A4	G5	TP11	10	D1	H4	U228	4	B2	B4					
C5	8	G4	D1	C256	5	E5	J3	C299	8	E4	F6	CR11	8	C1	G8	J126	8	A2	D8	Q100	8	D4	F8	R261	8	D4	F6	R323	10	C3	G5	TP13	4	H5	C8	U229	4	B2	C4					
C6	8	G4	D1	C257	5	E5	J2	C300	8	E3	F5	CR12	8	C1	G6	J128	8	H2	G5					R262	8	D3	G7	R325	10	D4	J4	TP14	10	D3	I4	U235	9	F1	D5					
C7	8	G4	E1	C258	5	E5	J1	C301	8	E4	E6	CR13	8	C1	G8	J130	10	C3	G5	R14	8	E2	E8	R263	8	C4	F6	R327	9	E3	E5	TP16	9	H5	E4	U236	9	B1	D7					
C8	8	H4	E2	C263	2	C4	A4	C302	8	D3	G6	CR40	8	D2	E7	J145	10	H3	K4	R15	8	E3	D7	R264	8	B4	E6	R328	10	E3	J4	TP17	2	A5	B3	U238	10	B3	F5					
C9	8	G4	I5	C268	8	C1	G8	C303	8	D3	G7	CR50	8	D3	E7	L2	5	F4	K3	R20	5	F4	K2	R265	8	B4	E6	R329	10	D4	J4	U2	5	F3	K3	U240	3	C3	C3					
C10	8	G3	H5	C269	8	F5	D7	C304	8	C4	F6	CR60	8	D3	F6	L4	2	C5	A4	R21	5	F4	K3	R266	8	B4	F6	R341	4	G1	C3	U22	3	G2	E2	U245	2	C1	A7					
C13	8	H3	H5	C270	8	G5	B5	C305	8	C4	F6	CR70	8	D4	G6	L28	8	G3	H5	R22	5	F4	K3	R267	8	B5	E6	R342	4	G1	C3	U24	3	G3	C1	VR30	8	C2	F6					
C15	8	H4	I5	C271	8	G5	C6	C306	8	C2	F6	CR71	8	E4	F6	L29	8	G4	I5	R23	5	F4	K3	R268	8	C5	E7	R343	4	G1	D3	U26	3	G4	D1	W155	4	E3	E3					
C20	5	F4	K3	C272	8	G5	C5	C307	8	B5	E6	CR80	8	B2	G6	L60	8	E3	F5	R24	5	F4	K3	R269	8	D5	E8	R344	4	G2	D3	U28	3	G1	D1	W156	4	E3	E3					
C21	5	F4	K3	C273	8	G5	C5	C308	8	C5	E6	CR81	8	B2	G7	L70	8	E4	F6	R30	5	G2	K2	R270	8	C2	F6	R345	4	G2	D3	U29	5	B4	G2	W157	4	E4	E3					
C30	2	C5	B4	C274	8	G5	E5	C309	8	B1	G6	CR85	8	D2	E7	L71	2	C4	A4	R31	5	F4	L3	R271	8	C2	F6	R346	4	G2	D3	U31	5	B3	F2	W158	4	E4	E3					
C37	5	C4	F2	C275	8	H5	D3	C314	8	B2	G6	F1	8	A1	K7	L75	8	B2	G6	R42	2	C5	A3	R272	2	C3	A6	R347	4	G2	D3	U50	8	E3	E6	W159	4	E4	E3					
C38	5	C4	F3	C276	8	H5	E5	C320	10	C3	F4	F2	8	A2	G7	L81	10	E4	I4	R45	5	B3	G2	R273	5	E3	I3	R348	4	G2	D3	U102	3	B3	B7	W166	4	E4	E3					
C39	5	C4	F3	C277	8	F5	C7	C321	10	C4	F5	FL2	5	C3	H2	LF1	8	A1	L7	R46	5	C3	G2	R274				R349	4	G2	D3	U104	3	B2	C7	W167	4	E4	E4					
C40	5	B4	F2	C278	8	G5	C3	C322	10	C4	F5	FL4	10	C3	H4	P6	5	C3		R48	5	C4	F3	R275	5	E3	I3	R350	4	G2	D3	U106	2	B5	A3	W168	4	E5	E4					
C41	5	A4	G2	C281	8	G5	A5	C323	10	B4	G4	P10	8	A1		P10	8	A1		R49	5	B4	G2	R300	10	E4	J4	R351	4	G2	E3	U108	2	D4	B3	W169	4	E5	E4					
C42	5	B4	G2	C282	8	G5	A6	C324	10	B4	G4	J4	5	H2	K1	P11	8	A1		R50	5	B4	G2	R301	10	E4	J4	R352	4	G2	E3	U150	3	C2	B4	W179	4	E5	E4					
C43	5	B4	G2	C283	8	G5	A6	C325	10	B4	F5	J6	5	C3	G2	P40	8	F2		R51	5	B5	G2	R302	10	D4	J4	R357	2	B1	A6	U200	8	C4	E6	W180	2	A5	A3					
C183	8	C1	F8	C284	8	G5	D4	C326	10	E3	I5	J40	8	F2	D6	P50	8	F3		R52	5	A4	G2	R303	10	E3	J4	R358	2	C1	A6	U201	2	F3	B6	W181	3	B4	B7					
C186	5	F3	K3	C290	8	F2	E7	C327	10	D4	J4	J50	8	F3	E6	P60	8	F3		R53	5	B4	G2	R304	10	D3	I5	T1	8	B1	I7	U202	2	E1	A6	W182	3	B4	B6					
C188	5	F3	K2	C291	8	F3	E7	C328	10	E4	I5	J60	8	F3	E5	P70	8	F4		R54	5	B4	G2	R305	10	D3	I5	T2	8	D3	F7	U212	8	E2	D8	W183	10	G3	J3					
C190	5	F4	K3	C292	8	E3	D7	C329	10	E4	I4	J70	8	F4	E5	P110	2	B2		R140	8	C4	E7	R315	10	B3	G5	U220A	3	B1	A4	U220B	3	B1	A4	Y1	2	A5	B1					
C191	2	D5	B3	C293	8	E2	E7	C330	10	E3	J5	J106	5	H3	K3	P111	2	D1		R197	5	G3	K2	R316	10	B4	F5	U222	4	F1	D4													
C192	2	B5	A2	C294	8	E2	E7	C336	10	A4	G4	J107	2	A3	A6	P112	2	A1		R198	2	B5	A3	R317	10	B4	G5																	
C197	8	F4	B4	C295	8	E3	D7	C351	8	F5	E4	J110	2	B2	D7					R199	2	C5	A3	R318	10	B4	G4																	
								C352	8	G5	C3	J111	2	D1	D7					R231	2	C4	B3	R319	10	B4	G4																	

**Schematic Diagram <2>
Component Locator Chart**

The schematic diagram has an alpha-numeric grid to assist in locating parts within that diagram.

Assembly A2.

Partial Assembly A2 also shown on Diagrams 3, 4, 5, 8, 9, and 10.

Comp No	Diag Loc	Bd Loc
C30	C5	B4
C191	D5	B3
C192	B5	A2
C254	D5	A4
C255	D5	B4
C263	C4	A4
C356	C3	A6
J107	A3	A6
J110	B2	D7
J111	D1	D7
J112	A1	A5
J124	D3	C7
L4	C5	A4
L71	C4	A4
P110	B2	
P111	D1	
P112	A1	
P124	D3	
R42	C5	A3
R198	B5	A3
R199	C5	A3
R231	C4	B3
R232	B1	A5
R233	D1	D8
R273	C3	A6
R357	B1	A6
R358	C1	A6
TP8	A5	B3
TP17	A5	B3
U106	B5	A3
U108	D4	B3
U201	F3	B6
U202	E1	A6
U245	C1	A7
W180	A5	A3
Y1	A5	B1

DIGITAL TIMING

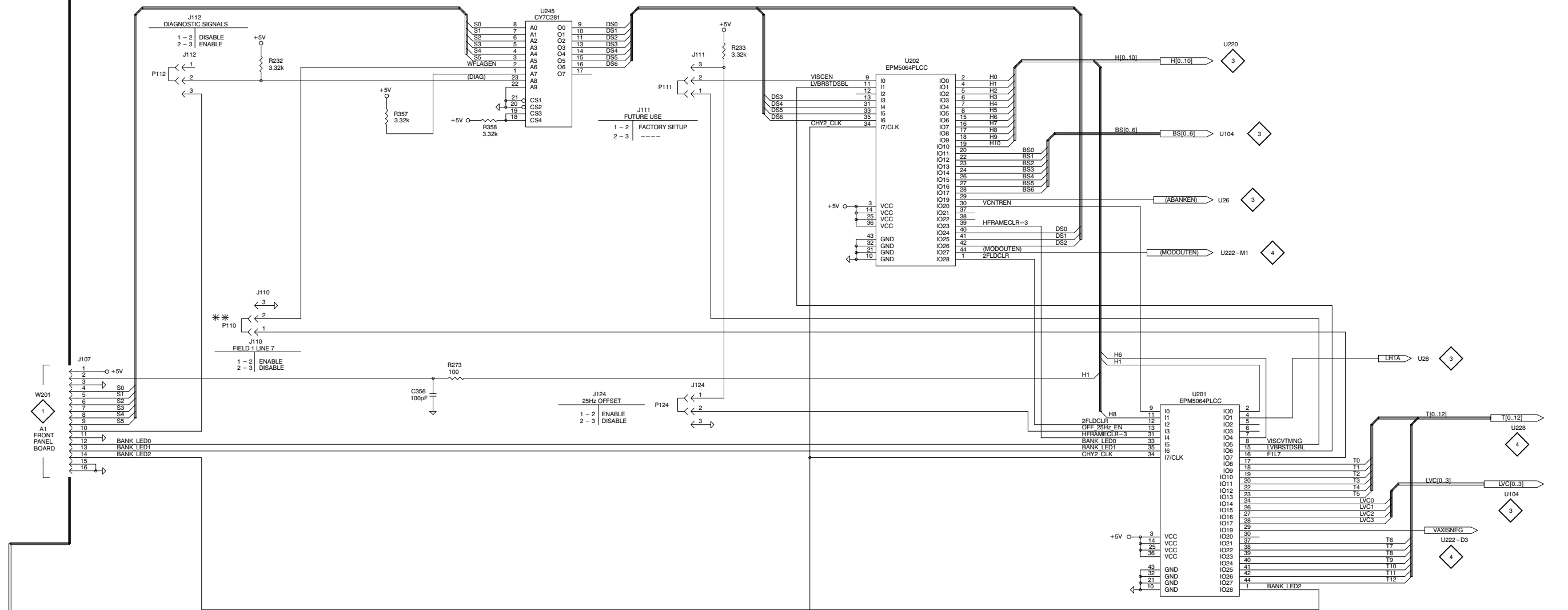

CLOCK PHASING

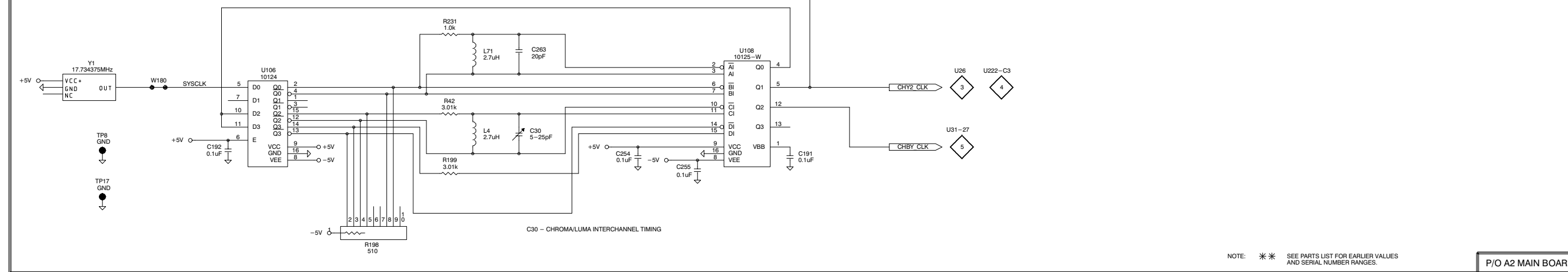

NOTE: ** SEE PARTS LIST FOR EARLIER VALUES AND SERIAL NUMBER RANGES.

P/O A2 MAIN BOARD

Schematic Diagram <3> Component Locator Chart

The schematic diagram has an alpha-numeric grid to assist in locating parts within that diagram.

Assembly A2.

Partial Assembly A2 also shown on Diagrams 2, 4, 5, 8, 9, and 10

Comp No	Diag Loc	Bd Loc	Comp No	Diag Loc	Bd Loc
TP9	A5	A7	U150	C2	B4
TP10	A5	E1	U220A	B1	A4
			U220B	B1	A4
U22	G2	E2	U240	C3	C3
U24	G3	C1			
U26	G4	D1	W181	B4	B7
U28	G1	D1	W182	B4	B6
U102	B3	B7			
U104	B2	C7			

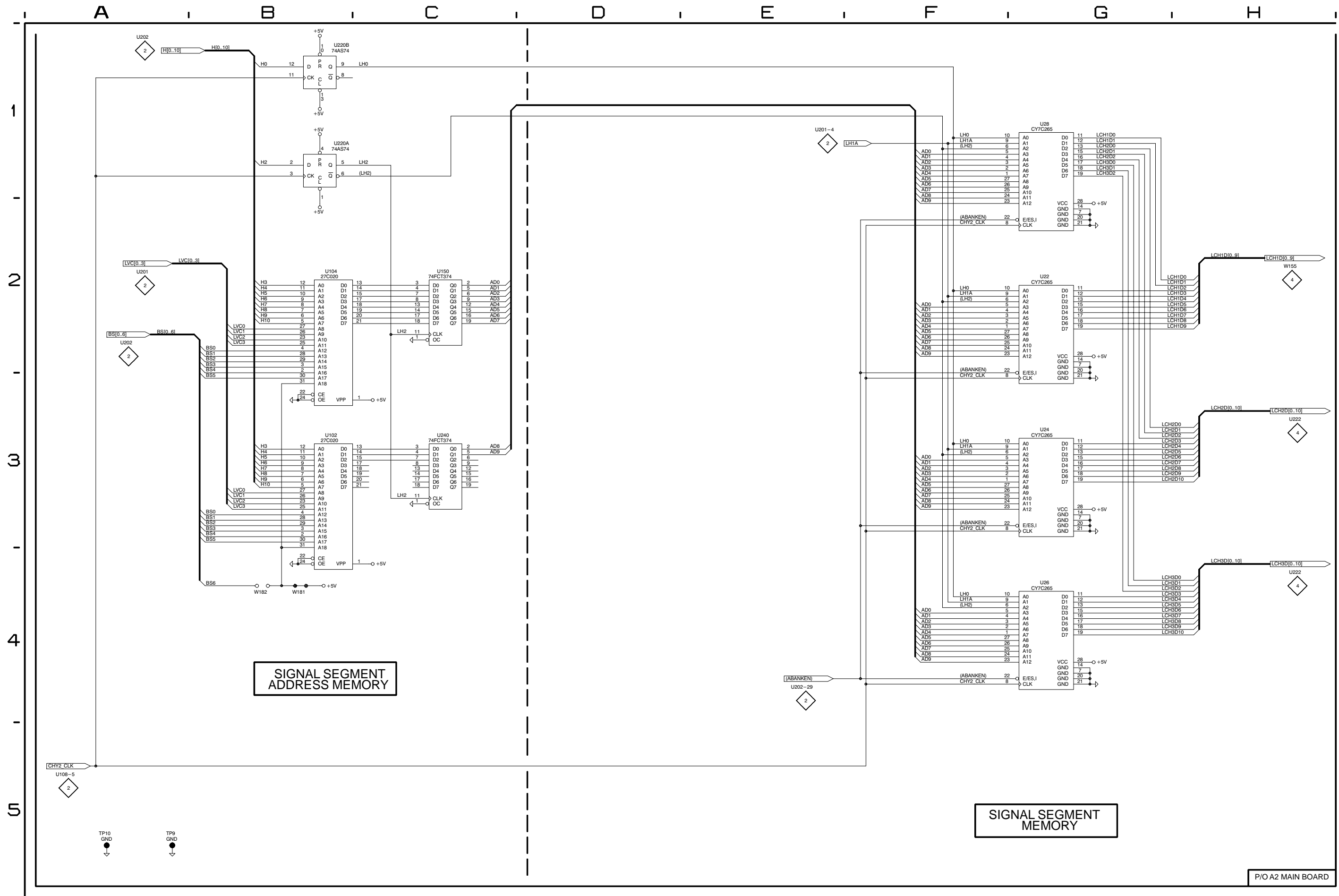

Schematic Diagram <4> Component Locator Chart

The schematic diagram has an alpha-numeric grid to assist in locating parts within that diagram.

Assembly A2.

Partial Assembly A2 also shown on Diagrams 2, 3, 5, 8, 9, and 10.

Comp No	Diag Loc	Bd Loc	Comp No	Diag Loc	Bd Loc
R248	E3	E3	U222	F1	D4
R341	G1	C3	U228	B2	B4
R342	G1	C3	U229	B2	C4
R343	G1	D3			
R344	G1	D3	W155	E3	E3
R345	G2	D3	W156	E3	E3
			W157	E4	E3
R346	G2	D3	W158	E4	E3
R347	G2	D3	W159	E4	E3
R348	G2	D3			
R349	G2	D3	W166	E4	E3
R350	G2	D3	W167	E4	E4
R351	G2	E3	W168	E5	E4
R352	G2	E3	W169	E5	E4
			W179	E5	E4
TP13	H5	C8			

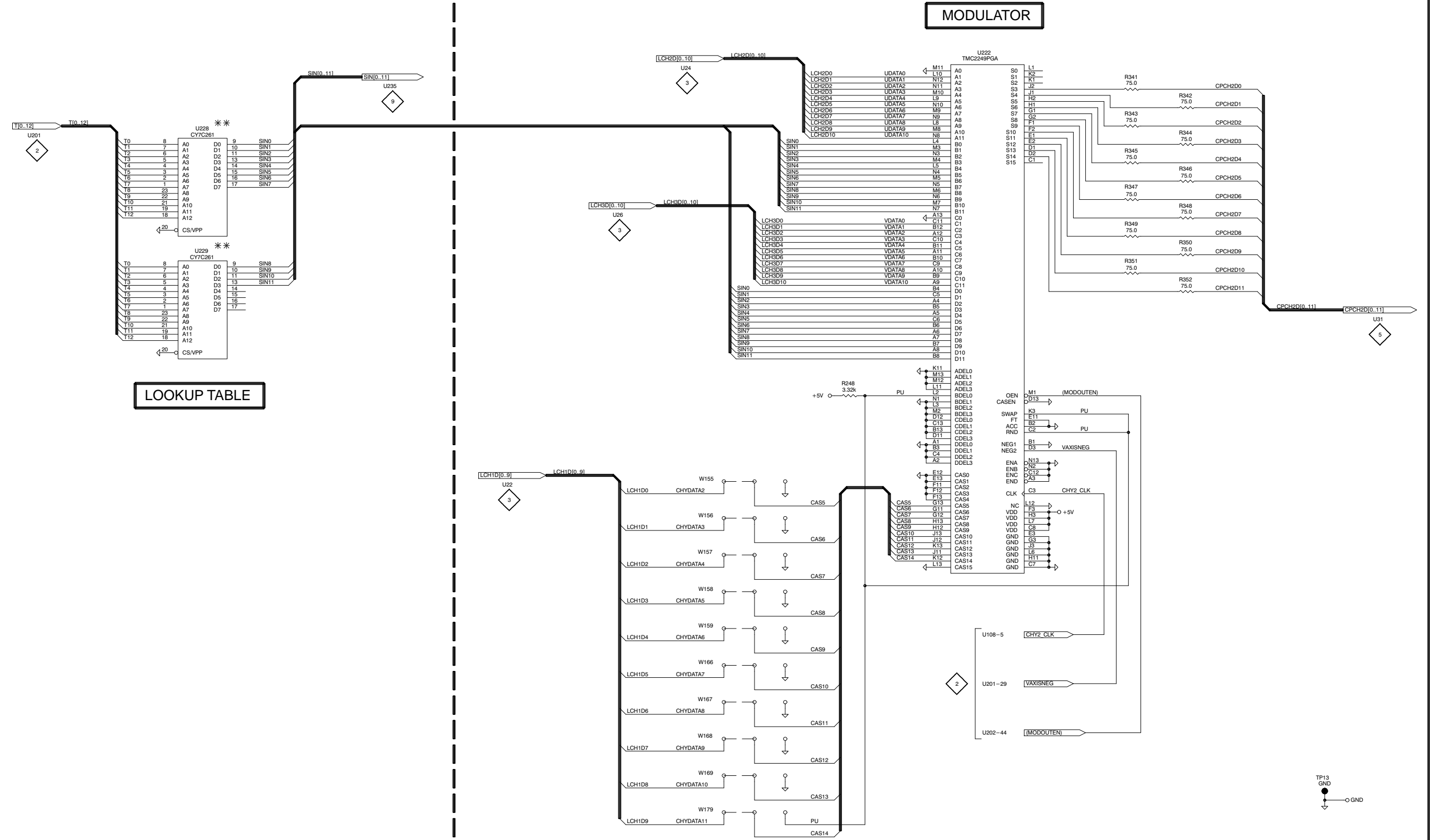

LOOKUP TABLE

MODULATOR

NOTE: ** SEE PARTS LIST FOR EARLIER VALUES AND SERIAL NUMBER RANGES.

P/O A2 MAIN BOARD

Schematic Diagram <5> Component Locator Chart

The schematic diagram has an alpha-numeric grid to assist in locating parts within that diagram.

Assembly A2.

Partial Assembly A2 also shown on Diagrams 2, 3, 4, 8, 9, and 10.

Comp No	Diag Loc	Bd Loc	Comp No	Diag Loc	Bd Loc
C20	F4	K3	R23	F4	K3
C21	F4	K3	R24	F4	K3
C37	C4	F2	R30	G2	K2
C38	C4	F3	R31	F4	L3
C39	C4	F3			
C40	B4	F2	R45	B3	G2
C41	A4	G2	R46	C3	G2
C42	B4	G2	R48	C4	F3
			R49	B4	G2
C43	B4	G2	R50	B4	G2
C186	F3	K3	R51	B5	G2
C188	F3	K2	R52	A4	G2
C190	F4	K3	R53	B4	G2
C256	E5	J3	R54	B4	G2
C257	E5	J2			
C258	E5	J1	R197	G3	K2
			R274	E3	I3
FL2	C3	H2			
			R275	E3	I3
J4	H2	K1			
J6	C3	G2	TP1	D3	I2
J106	H3	K3	TP5	D4	H2
L2	F4	K3	U2	F3	K3
			U29	B4	G2
P6	C3		U31	B3	F2
R20	F4	K2			
R21	F4	K3			
R22	F4	K3			

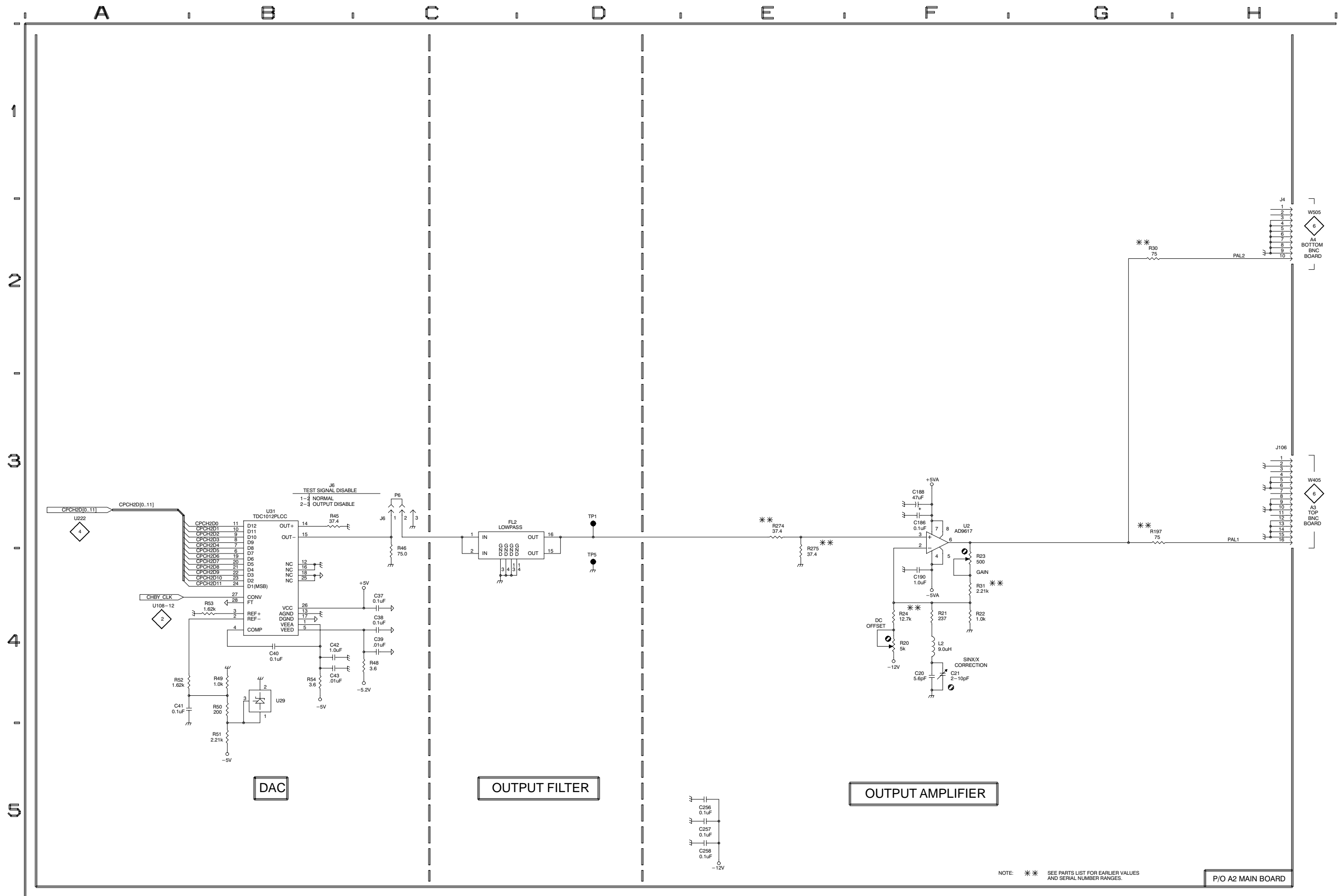

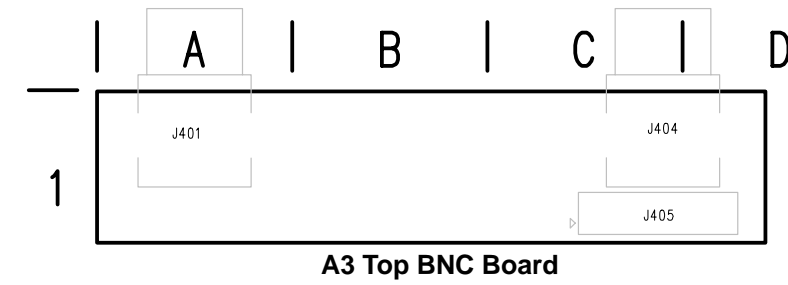

 **Static Sensitive Devices**
See Maintenance Section

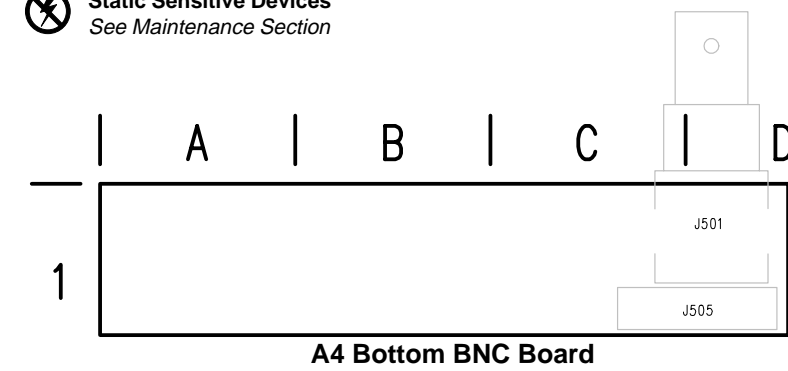

**A3 and A4 BNC Boards and Schematic Diagram <6>
Component Locator Chart**

The schematic diagram has an alpha-numeric grid to assist in locating parts within that diagram.

Assemblies A3 and A4.

Comp No	Diag Loc	Bd Loc
A3 Top BNC		
J401	H2	A1
J404	H2	C1
J405	A2	C1
W405	A2	
A4 Bottom BNC		
J501	H5	D1
J505	A4	D1
W505	A4	

A B C D E F G H

1

TOP BNC CONNECTORS

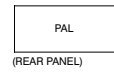
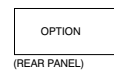
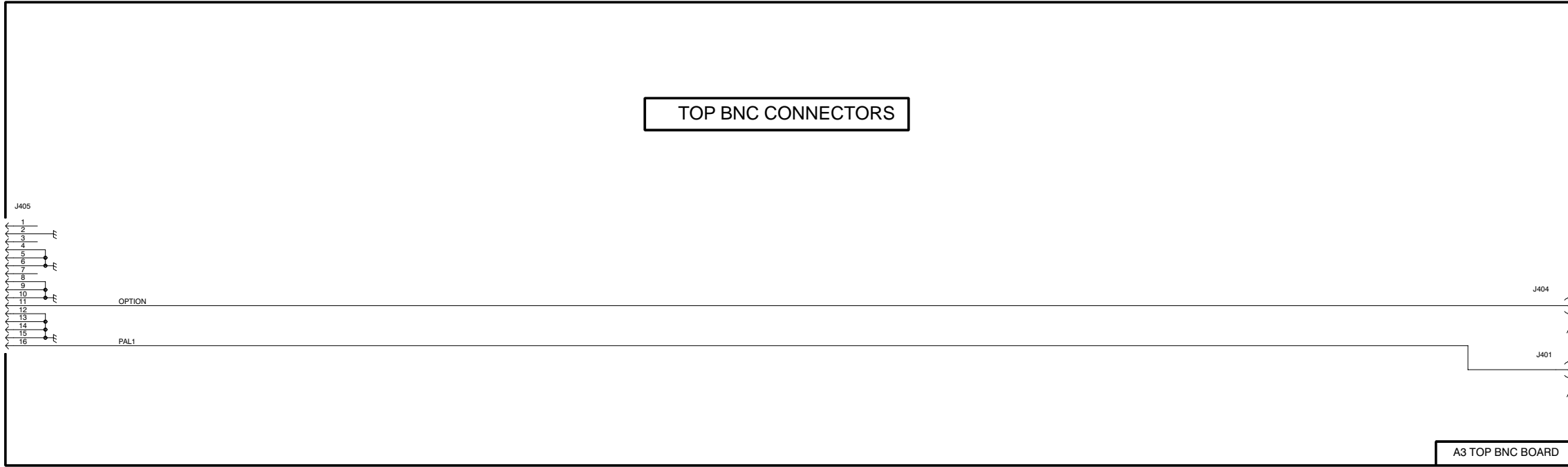
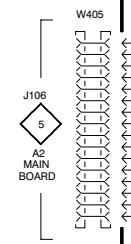

2

3

BOTTOM BNC CONNECTORS

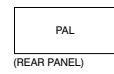
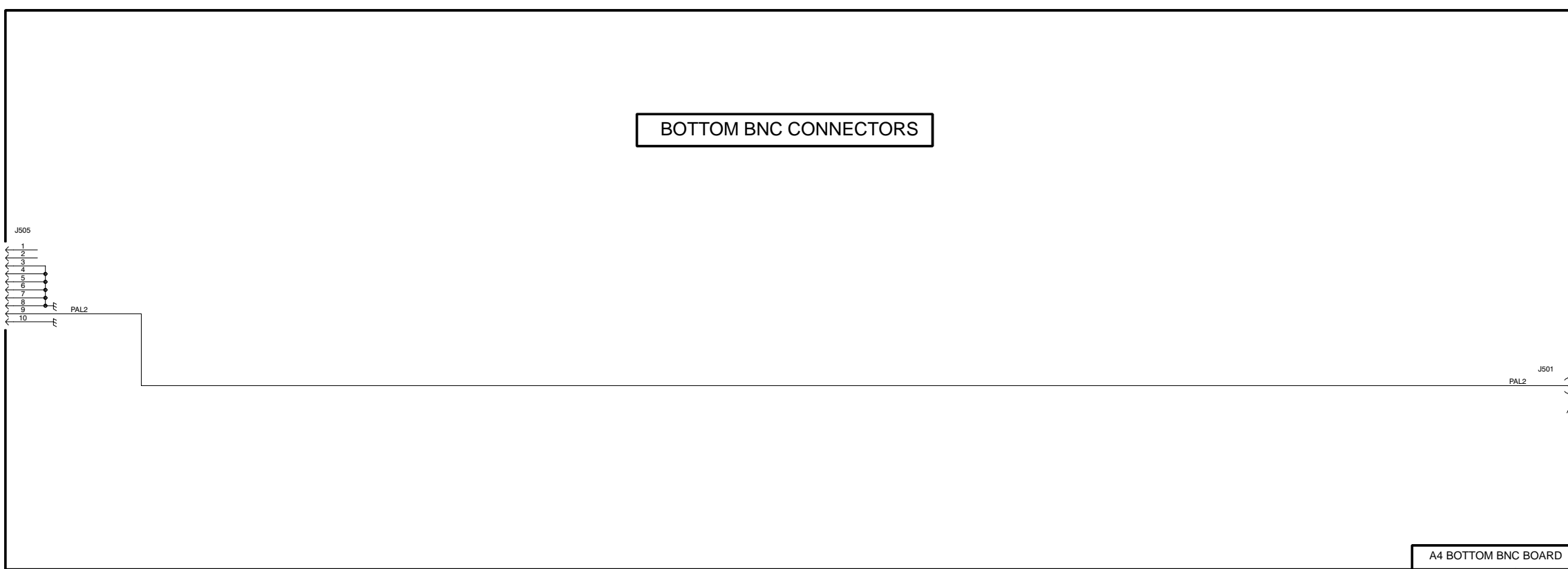
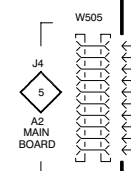

4

5

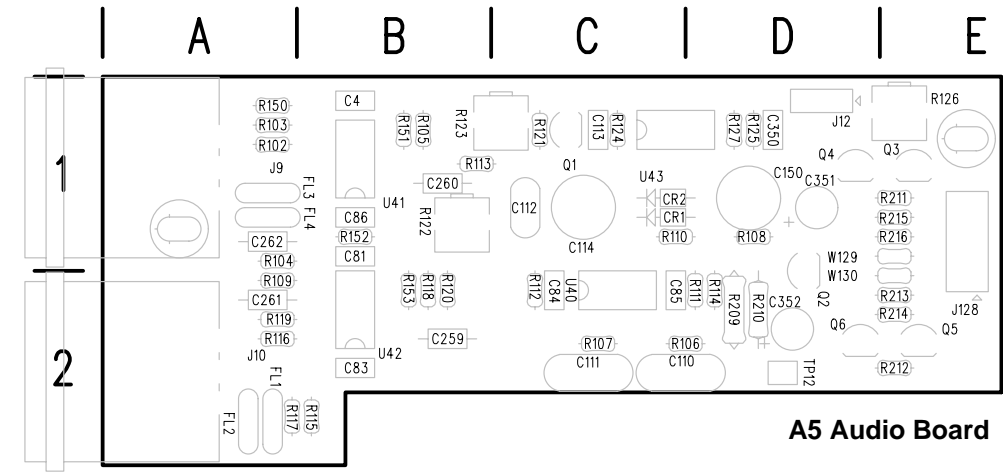

 **Static Sensitive Devices**
See Maintenance Section

Schematic Diagram <7> Component Locator Chart

The schematic diagram has an alpha-numeric grid to assist in locating parts within that diagram.

Assembly A5.

Comp No	Diag Loc	Bd Loc	Comp No	Diag Loc	Bd Loc	Comp No	Diag Loc	Bd Loc
C4	E3	B1	J128	A3	E1	R124	D3	C1
C81	E1	B1				R125	C3	D1
C83	E1	B2	P12	B3		R126	C3	E1
C84	B1	C2				R127	C3	D1
C85	B1	C2	Q1	D3	C1	R150	F4	A1
C86	E3	B1	Q2	Δ		R151	E3	B1
C110	B1	C2	Q3	Δ		R152	F2	B1
C111	B1	C2	Q4	Δ		R153	E1	B2
C112	D1	C1	Q5	Δ		R209	B2	D2
C113	D3	C1	Q6	Δ		R210	B2	D2
						R211	Δ	
C114	C3	C1	R102	G3	A1	R212	Δ	
C150	B2	D1	R103	F3	A1	R213	Δ	
C259	E1	B2	R104	G3	A1	R214	Δ	
C260	E3	B1	R105	D3	B1	R215	Δ	
C261	F1	A2	R106	B1	C2	R216	Δ	
C262	F3	A1	R107	B1	C2			
C350	B3	D1	R108	B2	D1	TP12	A3	D2
C351	C4	D1	R109	F3	A2			
C352	C5	D2	R110	C2	C1	U40A	B1	C2
			R111	B2	D2	U40B	C2	C2
CR1	C2	C1				U41A	E3	B1
CR2	C2	C1	R112	C2	C2	U41B	F3	B1
			R113	E2	B1	U42A	E1	B2
FL1*	G1	A2	R114	B2	D2	U42B	F2	B2
FL2*	G2	A2	R115	G1	B2	U43	C3	C1
FL3*	G3	A1	R116	F2	A2			
FL4*	G3	A1	R117	G2	A2	W128	A3	
			R118	D1	B2	W129	C4	E1
			R119	F1	A2	W130	C5	E2
			R120	E1	B2			
J9	H3	A1	R121	D2	C1			
J10	H1	A2	R122	E1	B1			
J12	B3	D1	R123	E2	B1			

* Check parts list for starting/ending S/N.
Δ Not used on TSG 111.

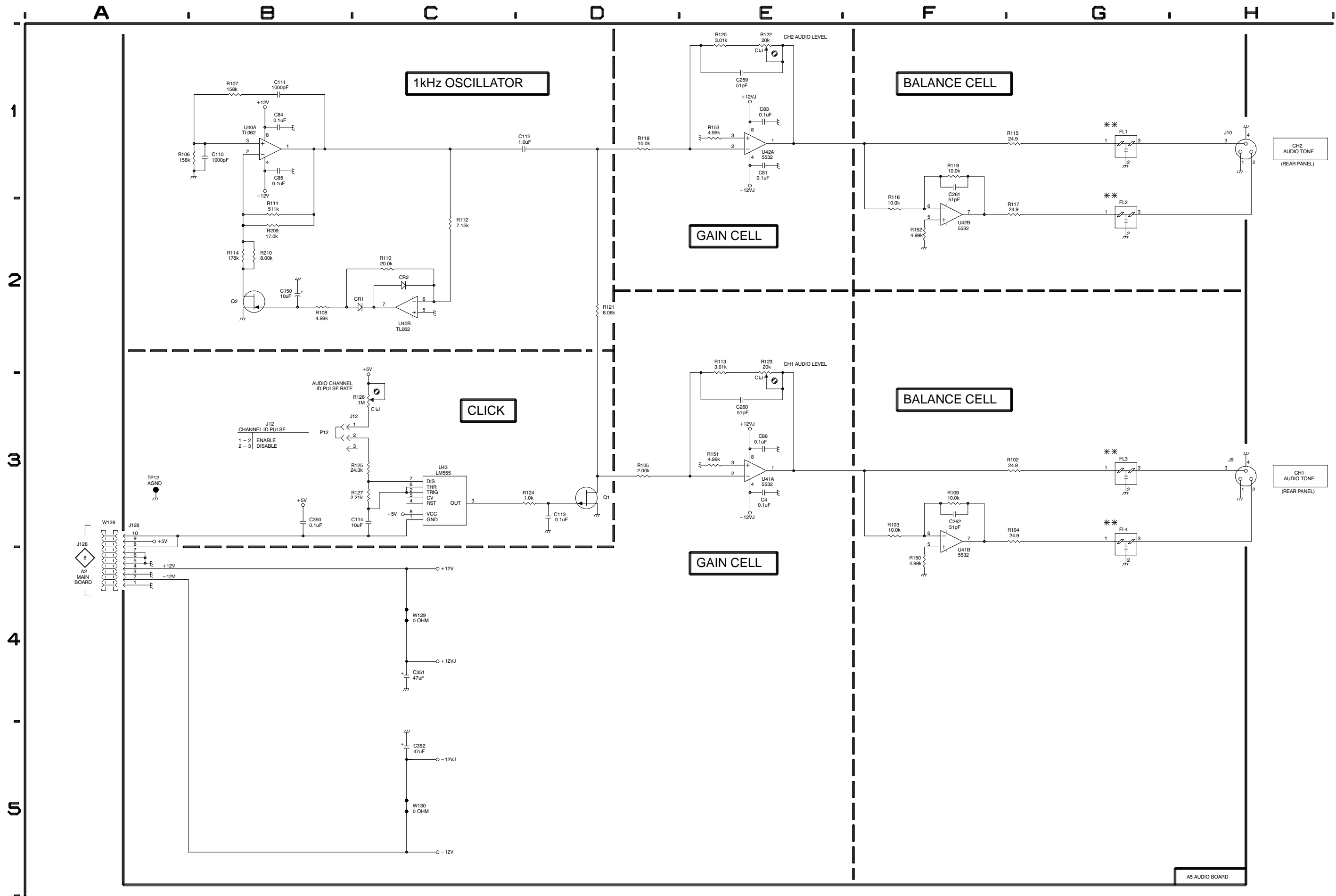

Schematic Diagram <8> Component Locator Chart

The schematic diagram has an alpha-numeric grid to assist in locating parts within that diagram.

Assembly A2.

Partial Assembly A2 also shown on Diagrams 2, 3, 4, and 5.

Comp No	Diag Loc	Bd Loc	Comp No	Diag Loc	Bd Loc
C1	F4	B8	CR50	D3	E7
C2	G4	C8	CR60	D3	F6
C3	G4	C1	CR70	D4	G6
C5	G4	D1	CR71	E4	F6
C6	G4	D1	CR80	B2	G6
C7	G4	E1	CR81	B2	G7
C8	H4	E2	CR85	D2	E7
C9	G4	I5			
C10	G3	H5	F1	A1	K7
C13	H3	H5	F2	A2	G7
C15	H4	I5	J40	F2	D6
C183	C1	F8	J50	F3	E6
C197	F4	B4	J60	F3	E5
C198	G4	C4	J70	F4	E5
C268	C1	G8	J122	B1	K6
C269	F5	D7	J126	A2	D8
C270	G5	B5	J128	H2	G5
C271	G5	C6			
C272	G5	C5	L28	G3	H5
C273	G5	C5	L29	G4	I5
			L60	E3	F5
C274	G5	E5	L70	E4	F6
C275	H5	D3	L75	B2	G6
C276	H5	E5			
C277	F5	C7	LF1	A1	L7
C278	G5	C3			
C281	G5	A5	P10	A1	
C282	G5	A6	P11	A1	
C283	G5	A6	P40	F2	
C284	G5	D4	P50	F3	
C290	F2	E7	P60	F3	
			P70	F4	
C291	F3	E7	P122	A1	
C292	E3	D7			
C293	E2	E7	Q30	C2	F6
C294	E2	E7	Q100	D4	F8
C295	E3	D7			
C296	E3	G5	R14	E2	E8
C297	E4	G6	R15	E3	D7
C298	E3	F5	R140	C4	E7
C299	E4	F6	R261	D4	F6
C300	E3	F5	R262	D3	G7
			R263	C4	F6
C301	E4	E6	R264	B4	E6
C302	D3	G6	R265	B4	E6
C303	D3	G7	R266	B4	F6
C304	C4	F6	R267	B5	E6
C305	C4	F6	R268	C5	E7
C306	C2	F6	R269	D5	E8
C307	B5	E6	R270	C2	F6
C308	C5	E6	R271	C2	F6
C309	B1	G6			
C314	B2	G6	T1	B1	I7
			T2	D3	F7
C351	F5	E4	U50	E3	E6
C352	G5	C3	U200	C4	E6
C353	G5	E4	U212	E2	D8
CR10	C1	G6			
CR11	C1	G8			
CR12	C1	G6	VR30	C2	F6
CR13	C1	G8			
CR40	D2	E7			

A B C D E F G H

1
2
3
4
5

**RECTIFIER AND INPUT TRANSFORMER
110/220 SWITCH**

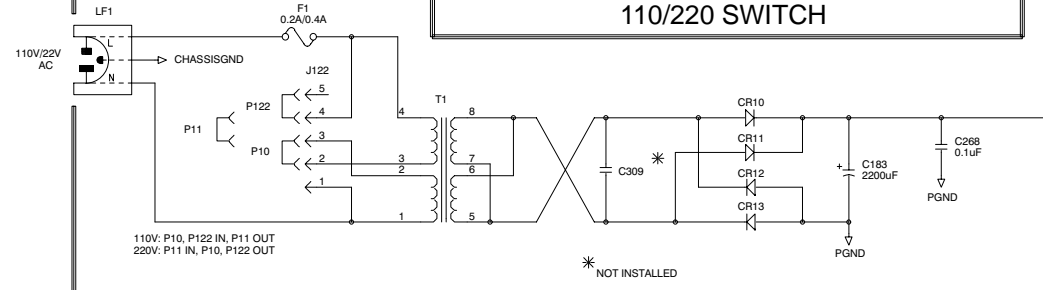

OUTPUTS, RECTIFIERS, AND FILTERS

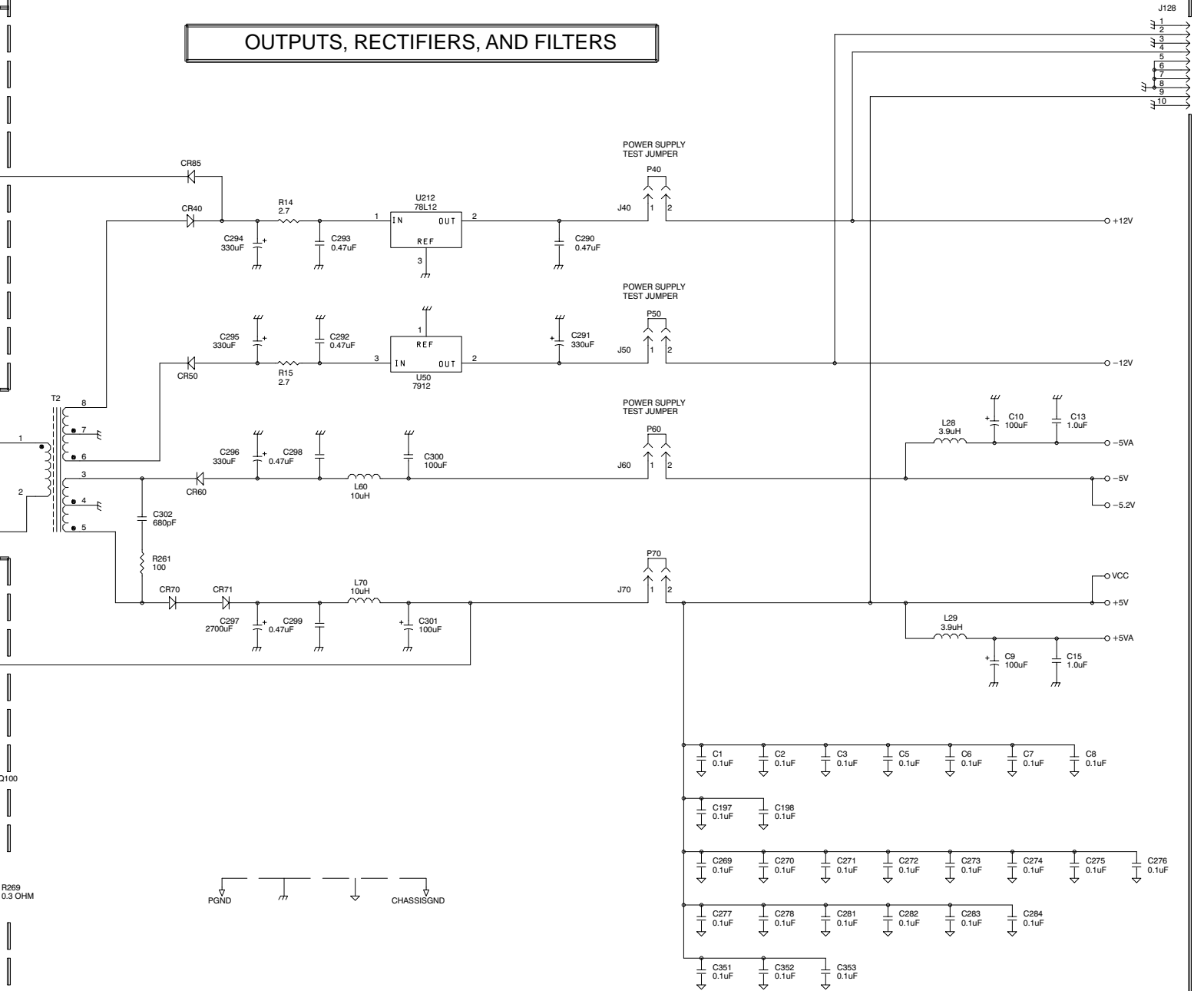

HOUSEKEEPING

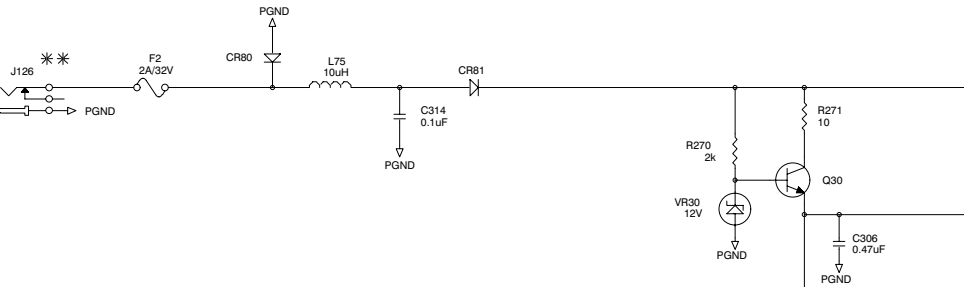

REGULATOR

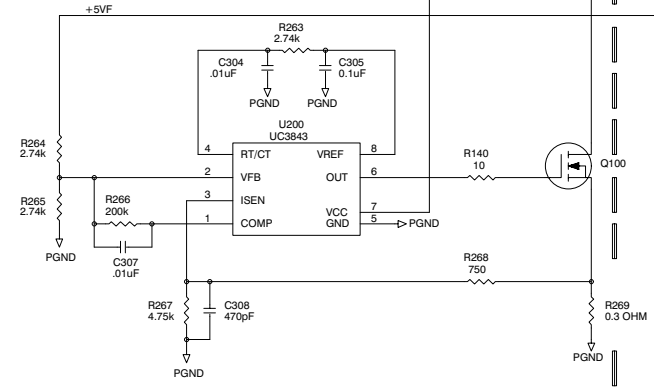

NOTE: ** SEE PARTS LIST FOR EARLIER VALUES AND SERIAL NUMBER RANGES.

P/O A2 MAIN BOARD

Schematic Diagram <9> Component Locator Chart

The schematic diagram has an alpha-numeric grid to assist in locating parts within that diagram.

Assembly A2.

Partial Assembly A2 also shown on Diagrams 2, 3, 4, 5, 8, and 10.

<i>Comp No</i>	<i>Diag Loc</i>	<i>Bd Loc</i>
R327	E3	E5
TP16	H5	E4
U235	F1	D5
U236	B1	D7

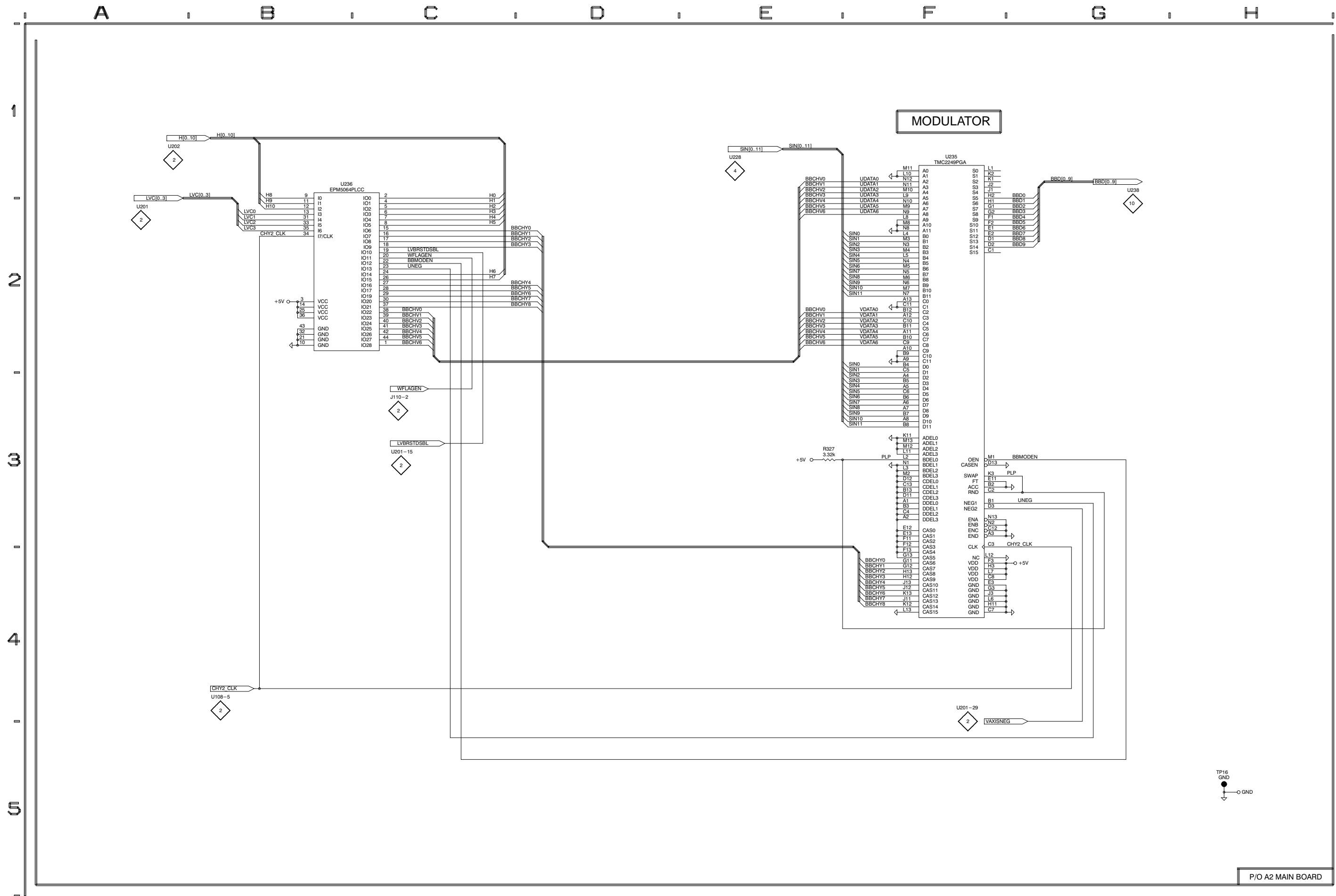

Schematic Diagram <10> Component Locator Chart

The schematic diagram has an alpha-numeric grid to assist in locating parts within that diagram.

Assembly A2.

Partial Assembly A2 also shown on Diagrams 2, 3, 4, 5, 8, and 9.

<i>Comp No</i>	<i>Diag Loc</i>	<i>Bd Loc</i>
C320	C3	F4
C321	C4	F5
C322	C4	F5
C323	B4	G4
C324	B4	G4
C325	B4	F5
C326	E3	I5
C327	D4	J4
C328	E4	I5
C329	E4	I4
C330	E3	J5
C336	A4	G4
FL4	C3	H4
J130	C3	G5
J145	H3	K4
L81	E4	I4
P130	C3	
R300	E4	J4
R301	E4	J4
R302	D4	J4
R303	E3	J4
R304	D3	I5
R305	D3	I5
R315	B3	G5
R316	B4	F5
R317	B4	G5
R318	B4	G4
R319	B4	G4
R320	B4	G4
R321	A3	G5
R322	A4	G5
R323	C3	G5
R325	D4	J4
R328	E3	J4
R336	G3	J4
TP11	D1	H4
TP14	D3	I4
U225	E3	J5
U227	B4	G4
U238	B3	F5
W183	G3	J3

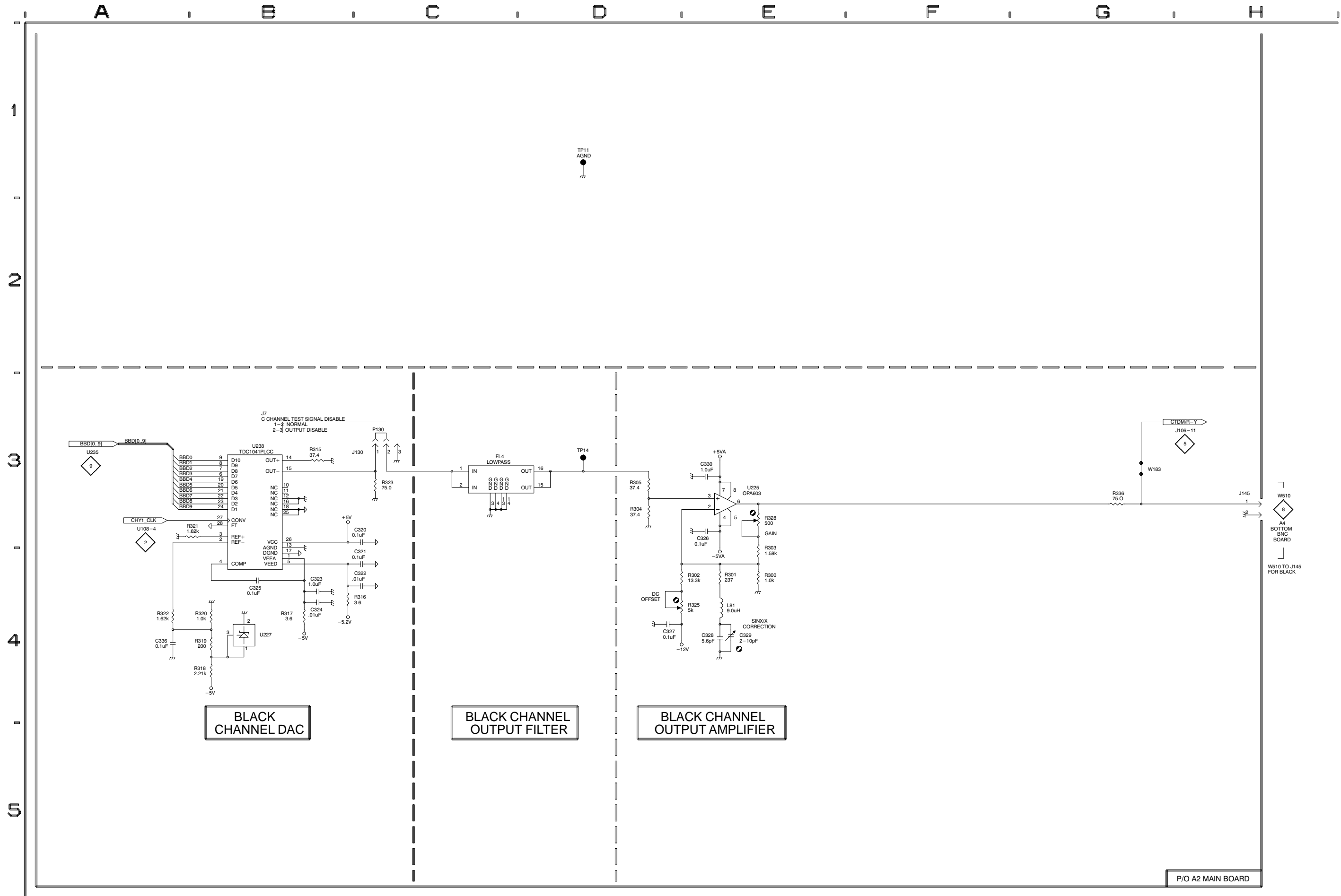
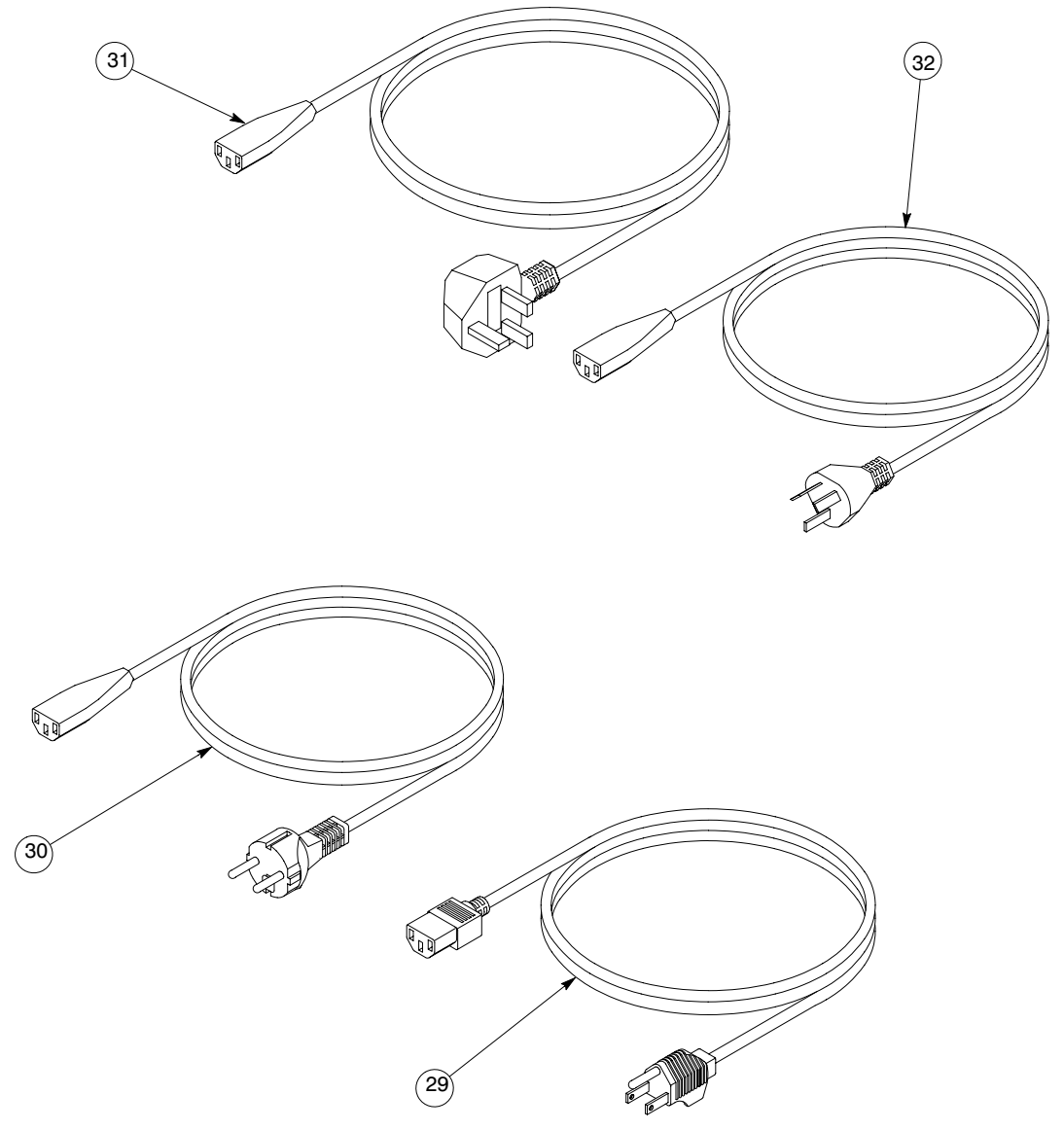
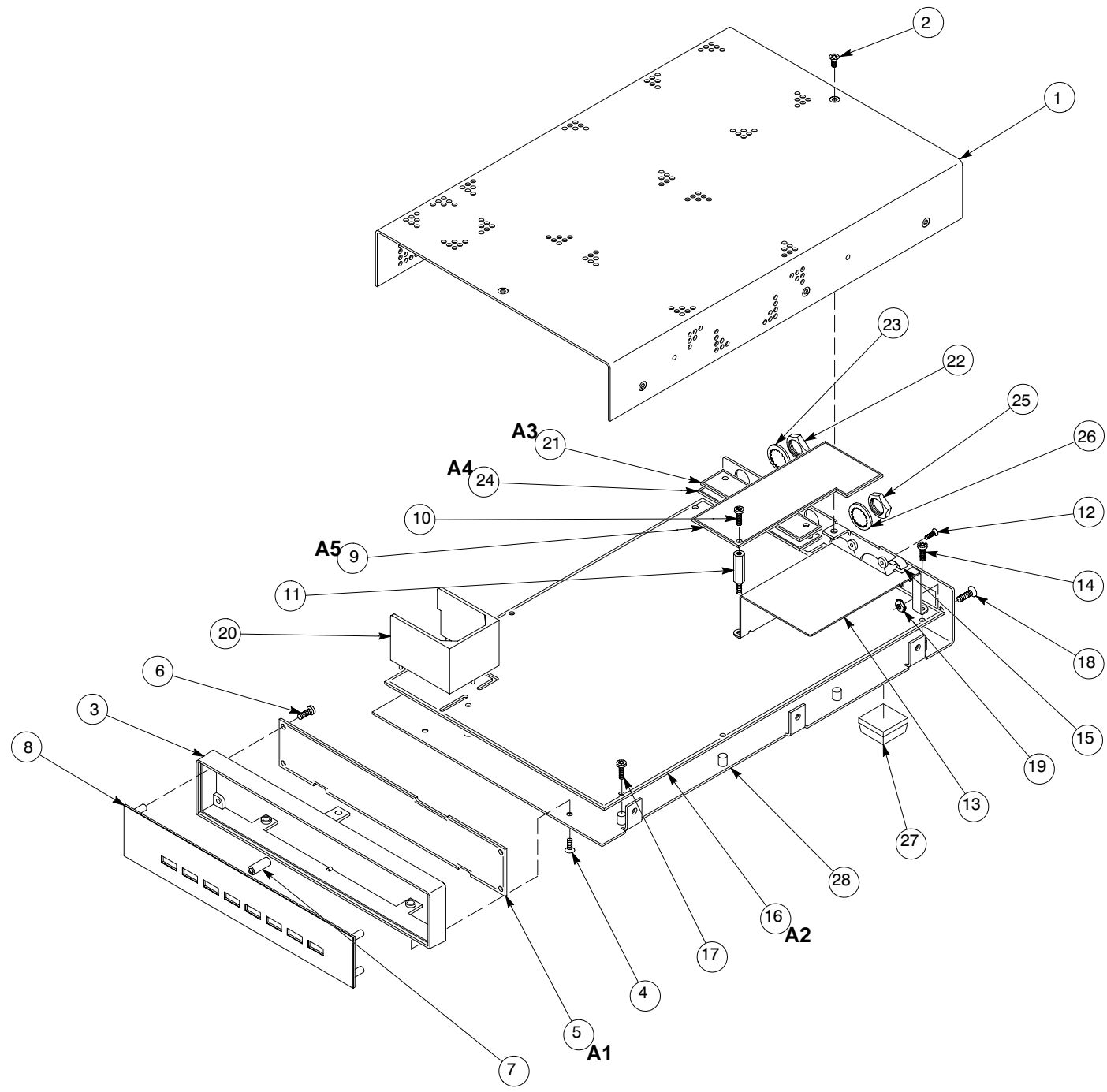

FIG. 1 EXPLODED VIEW





Replaceable Mechanical Parts

Replaceable Mechanical Parts

This section contains a list of the components that are replaceable for the TSG 111. Use this list to identify and order replacement parts. There is a separate Replaceable Mechanical Parts list for each instrument.

Parts Ordering Information

Replacement parts are available from or through your local Tektronix, Inc., Field Office or representative.

Changes to Tektronix instruments are sometimes made to accommodate improved components as they become available and to give you the benefit of the latest circuit improvements. Therefore, when ordering parts, it is important to include the following information in your order.

- Part number
- Instrument type or model number
- Instrument serial number
- Instrument modification number, if applicable

If a part you have ordered has been replaced with a new or improved part, your local Tektronix, Inc., Field Office or representative will contact you concerning any change in part number.

Change information, if any, is located at the rear of this manual.

Using the Replaceable Mechanical Parts List

The tabular information in the Replaceable Mechanical Parts list is arranged for quick retrieval. Understanding the structure and features of the list will help you find all of the information you need for ordering replaceable parts.

Cross Index–Mfr. Code Number to Manufacturer

The Mfg. Code Number to Manufacturer Cross Index for the mechanical parts list is located immediately after this page. The cross index provides codes, names, and addresses of manufacturers of components listed in the mechanical parts list.

Abbreviations

Abbreviations conform to American National Standards Institute (ANSI) standard Y1.1.

Chassis Parts Chassis-mounted parts and cable assemblies are located at the end of the Replaceable Electrical Parts list.

Column Descriptions

Figure & Index No. (Column 1) Items in this section are referenced by figure and index numbers to the illustrations.

Tektronix Part No. (Column 2) Indicates part number to be used when ordering replacement part from Tektronix.

Serial No. (Column 3 and 4) Column three (3) indicates the serial number at which the part was first used. Column four (4) indicates the serial number at which the part was removed. No serial number entered indicates part is good for all serial numbers.

Qty (Column 5) This indicates the quantity of mechanical parts used.

Name and Description (Column 6) An item name is separated from the description by a colon (:). Because of space limitations, an item name may sometimes appear as incomplete. Use the U.S. Federal Catalog handbook H6-1 for further item name identification.

Following is an example of the indentation system used to indicate relationship.

1	2	3	4	5	Name & Description
					Assembly and/or Component
					Mounting parts for Assembly and/or Component
					MOUNTING PARTS/*END MOUNTING PARTS*
					Detail Part of Assembly and/or Component
					Mounting parts for Detail Part
					MOUNTING PARTS/*END MOUNTING PARTS*
					Parts of Detail Part
					Mounting parts for Parts of Detail Part
					MOUNTING PARTS/*END MOUNTING PARTS*

Mounting Parts always appear in the same indentation as the Item it mounts, while the detail parts are indented to the right. Indented items are part of and included with, the next higher indentation. **Mounting parts must be purchased separately, unless otherwise specified.**

Mfr. Code (Column 7) Indicates the code number of the actual manufacturer of the part. (Code to name and address cross reference can be found immediately after this page.)

Mfr. Part Number (Column 8) Indicates actual manufacturer's part number.

Cross Index – Mfr. Code Number To Manufacturer

Mfr. code	Manufacturer	Address	City, state, zip code
S3109	FELLER	72 Veronica Ave Unit 4	Summerset NJ 08873
TK0435	LEWIS SCREW CO	4300 S RACINE AVE	CHICAGO IL 60609-3320
TK0588	UNIVERSAL PRECISION PRODUCTS	1775 NW 216TH	HILLSBORO OR 97123
TK1155	QUALITY PLASTIC INJECTION MOLDING	3910 INDUSTRIAL AVE	COEUR D'ALENE ID 83814
TK1295	DAVIS TOOL INC	215 SW WOOD ST	HILLSBORO OR 97123
TK2548	XEROX BUSINESS SERVICES DIV OF XEROX CORPORATION	14181 SW MILLIKAN WAY	BEAVERTON OR 97077
0J7N4	ARCHER PRECISION SHEET METAL INC	10950 SW 5TH ST	BEAVERTON OR 97005
0KB01	STAUFFER SUPPLY	810 SE SHERMAN	PORTLAND OR 97214
0KB05	NORTH STAR NAMEPLATE	5750 NE MOORE COURT	HILLSBORO OR 97124-6474
07416	NELSON NAME PLATE CO	3191 CASITAS	LOS ANGELES CA 90039-2410
52152	MINNESOTA MINING AND MFG CO INDUSTRIAL TAPE DIV	3M CENTER	ST PAUL MN 55144-0001
55566	R A F ELECTRONIC HARDWARE INC	95 SILVERMINE RD	SEYMOUR CT 06483-3915
73743	FISCHER SPECIAL MFG CO	111 INDUSTRIAL RD	COLD SPRING KY 41076-9749
80009	TEKTRONIX INC	14150 SW KARL BRAUN DR PO BOX 500	BEAVERTON OR 97077-0001

Replaceable Mechanical Parts

Fig. & index no.	Tektronix part no.	Serial number Effective	Dscont	Qty	12345 name & description	Mfr. code	Mfr. part no.
1-1	200-4132-00			1	COVER, TOP: 12.188 X 8.120; TSG111 *MOUNTING PARTS*	80009	200413200
-2	211-0119-00			8	SCREW, MACHINE: 4-40 X 0.25, FLH, 100 DEG, STL *END MOUNTING PARTS*	TK0435	ORDER BY DESC
-3	426-2420-01			1	FRAME, FRONT: ALUMINUM *MOUNTING PARTS*	80009	426242001
-4	211-0119-00			2	SCREW, MACHINE: 4-40 X 0.25, FLH, 100 DEG, STL *END MOUNTING PARTS*	TK0435	ORDER BY DESC
-5	-----			1	CIRCUIT BD ASSY: FRONT PANEL (SEE A1 REPL) *MOUNTING PARTS*		
-6	211-0244-00			5	SCR, ASSEM WSHR: 4-40 X 0.312, PNH, STL, CD PL, POZ, MACHINE	TK0435	7772-312
-7	129-1411-00			1	SPACER, POST: 0.280 X 0.200, ABS *END MOUNTING PARTS*	TK0588	129-1411-00
-8	333-3970-00			1	PANEL, FRONT: TSG111	07416	333-3970-00
-9	-----			1	CIRCUIT BD ASSY: AUDIO (SEE A5 REPL) *ATTACHED PARTS*		
	214-4528-01				SPRING, GROUND, STAINLESS STEEL *END ATTACHED PARTS*		
		B030000			*MOUNTING PARTS*		
-10	211-0244-00			1	SCR, ASSEM WSHR: 4-40 X 0.312, PNH, STL, CD PL, POZ, MACHINE *END MOUNTING PARTS*	TK0435	7772-312
-11	129-1394-00			1	SPACER, POST: 1.05 SPACING, 4-40 INT & 4-40 X 0.187 EXT THD, 0.250 HEX, STAINLESS STEEL	55566	4542-440-SS-20
-12	211-0101-00			4	SCREW, MACHINE: 4-40 X 0.25, FLH, 100 DEG, STL	TK0435	ORDER BY DESC
-13	337-3784-00		B030995	1	SHIELD, ELEC: TSG131A	TK1295	337-3784-00
-13	337-3784-01	B030996		1	SHIELD, ELEC: TSG131A *MOUNTING PARTS*	TK1295	337-3784-01
-14	211-0244-00			1	SCR, ASSEM WSHR: 4-40 X 0.312, PNH, STL, CD PL, POZ, MACHINE *END MOUNTING PARTS*	TK0435	7772-312
-15	337-3892-00			1	SHIELD, ELEC: BE CU, CLIP ON, 1 X 60	80009	337389200
-16	-----			1	CIRCUIT BD ASSY: MAIN (SEE A2 REPL) *MOUNTING PARTS*		
-17	211-0244-00			9	SCR, ASSEM WSHR: 4-40 X 0.312, PNH, STL, CD PL, POZ, MACHINE	TK0435	7772-312
-18	211-0025-00			2	SCREW, MACHINE: 4-40 X 0.375, FLH, 100 DEG, STL	TK0435	ORDER BY DESC
-19	210-0586-00			2	NUT, PL, ASSEM WA: 4-40 X 0.25, STL CD PL *END MOUNTING PARTS*	TK0435	ORDER BY DESC
-20	337-3750-00			1	SHIELD, ELEC: PLASTIC	TK1155	337-3750-00
-21	-----			1	CIRCUIT BD ASSY: TOP BNC (SEE A3 REPL) *MOUNTING PARTS*		
-22	220-0497-00			2	NUT, PLAIN, HEX: 0.5-28 X 0.562 HEX, BRS CD PL	73743	ORDER BY DESC
-23	210-1039-00			2	WASHER, LOCK: 0.521 ID, INT, 0.025 THK, SST *END MOUNTING PARTS*	0KB01	1224-02-00-0541

Fig. & index no.	Tektronix part no.	Serial number Effective	Dscont	Qty	12345 name & description	Mfr. code	Mfr. part no.
-24	-----			1	CIRCUIT BD ASSY:BOTTOM BNC (SEE A4 REPL) *MOUNTING PARTS*		
-25	220-0497-00			1	NUT,PLAIN,HEX:0.5-28 X 0.562 HEX,BRS CD PL	73743	ORDER BY DESC
-26	210-1039-00			1	WASHER,LOCK:0.521 ID,INT,0.025 THK,SST *END MOUNTING PARTS*	0KB01	1224-02-00-0541
-27	348-0844-00			4	PAD,CUSHIONING:0.05 SQ X 0.23 H,POLYURETHANE W/PRESSURE SENS ADHESIVE	52152	SJ-5018-GRAY
-28	200-3964-00		B029999	1	COVER,BOTTOM:TSG111	0J7N4	200-3964-00
	200-3964-01	B030000		1	COVER,BOTTOM:TSG111	0J7N4	200-3964-01
	334-8408-00			1	LABEL:LEXAN,LINE VOLTAGE SET FOR90-130V,SAFETY CONTROLLED	0KB05	334-8408-00
					STANDARD ACCESSORIES		
-29	161-0066-00			1	CA ASSY,PWR:3,18 AWG,250V/10A,98 INCH,STR,IEC320, RCPT X NEMA 5-15P,US,SAFTEY CONTROLLED (STANDARD ONLY)	S3109	161-0066-00
	070-8367-03			1	MANUAL,TECH:INSTRUCTION,TSG111	TK2548	PER TEK P/N
					OPTIONAL ACCESSORIES		
-30	161-0066-09			1	CA ASSY,PWR:3,0.75MM SQ,250V/10A,99 INCH,STR,IEC320, RCPT,EUROPEAN,SAFTEY CONTROLLED (EUROPEAN OPTION A1 ONLY)	S3109	86511000
-31	161-0066-10			1	CA ASSY,PWR:3,0.1MM SQ,250V/10A,2.5 METER,STR, IEC320,RCPT X 13A,FUSED UK PLUG(13A FUSE),UNITED KINGDOM,SAFTEY CONTROLLED (UNITED KINGDOM OPTION A2 ONLY)	S3109	BS/13-H05VVF3G0
-32	161-0066-11			1	CA ASSY,PWR:3,1.0MM SQ,250V/10A,2.5 METER,STR, IEC320,RCPT,AUSTRALIA,SAFTEY CONTROLLED (AUSTRALIAN OPTION A3 ONLY)	S3109	198-000
	-----			1	TVGF11A:RACK MOUNT KIT		

